

W4K2H-002

Combination Air Engaged Friction Clutch, Spring Engaged Friction Brake, Stop & Start the Integral Pulley



Clutch Engagement/Brake Engagement

Air/Spring

Facing Type

High Coefficient

Clutch Torque @ 80 PSI (max) – Dynamic

712 Pound Inches

Brake Torque @ Spring Pressure (fixed)

128 Pound Inches

Brake Release Pressure

20 - 25 PSI

Maximum RPM

1,750

Bore with Standard Keyway

16mm [0.630 Inches]

Air Volume New

0.47 Cubic Inches

Air Volume Worn

1.63 Cubic Inches

Finish

Aluminum

Open or Enclosed Construction

Open

Shipping Weight

12 Pounds

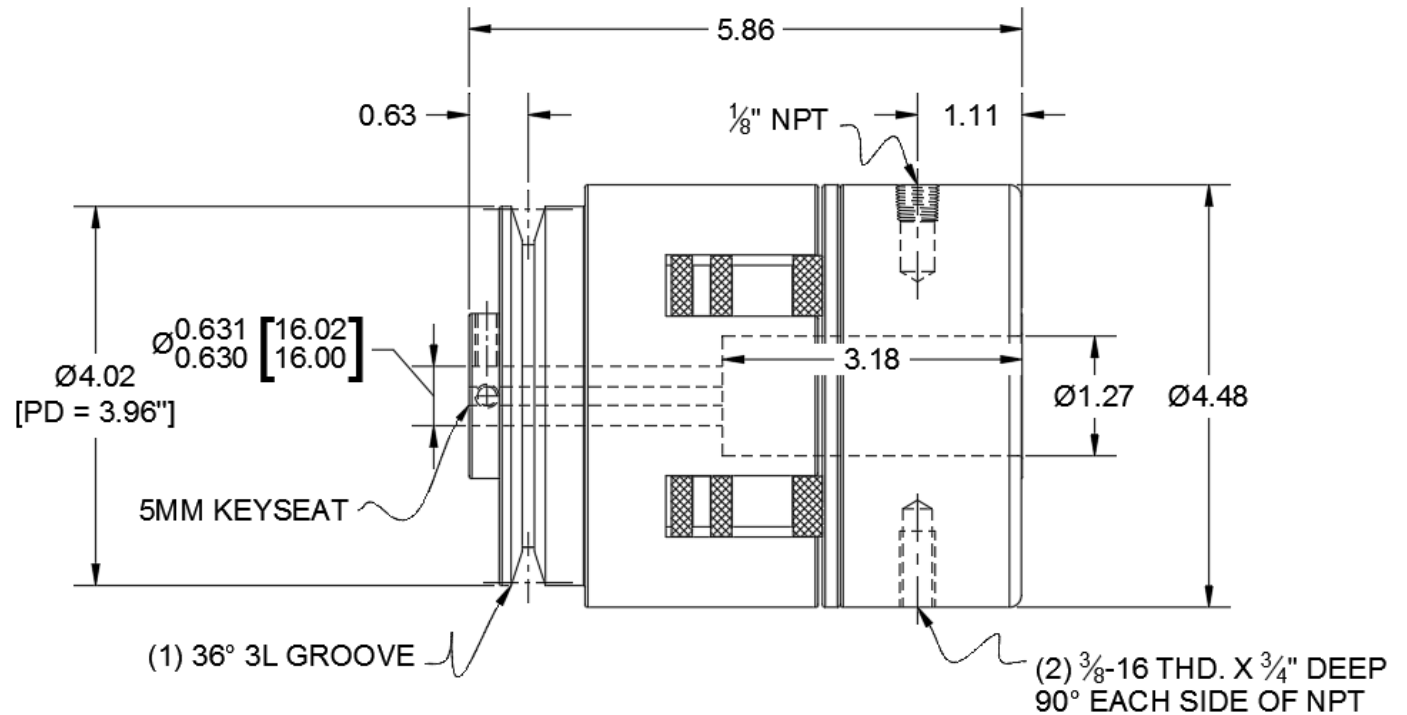

TORQUE vs. AIR PRESSURE

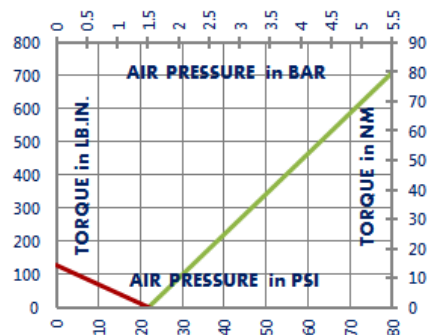

NEW vs. BURNISHED TORQUE

The torque output of a new friction brake or clutch can be up to 40% less than the published torque rating. To achieve full design torque, a unit must be cycled under load to burnish the friction surfaces. The exact number of cycles varies by application.

When calculating required torque always use a safety factor of 1.5 to 2. It is not recommended to select a product for use at its maximum rated torque for continuous duty.

PRODUCT SELECTION

Torque capacity is only one factor to consider when making a product selection. Ensure that you will have the right product for the job by contacting our engineering department for application review and selection assistance.



101 Cummings Drive
Walton, KY 41094 USA

859-291-0849

machiii.com

engineering@machiii.com

W4K2H-002

Parts Diagram

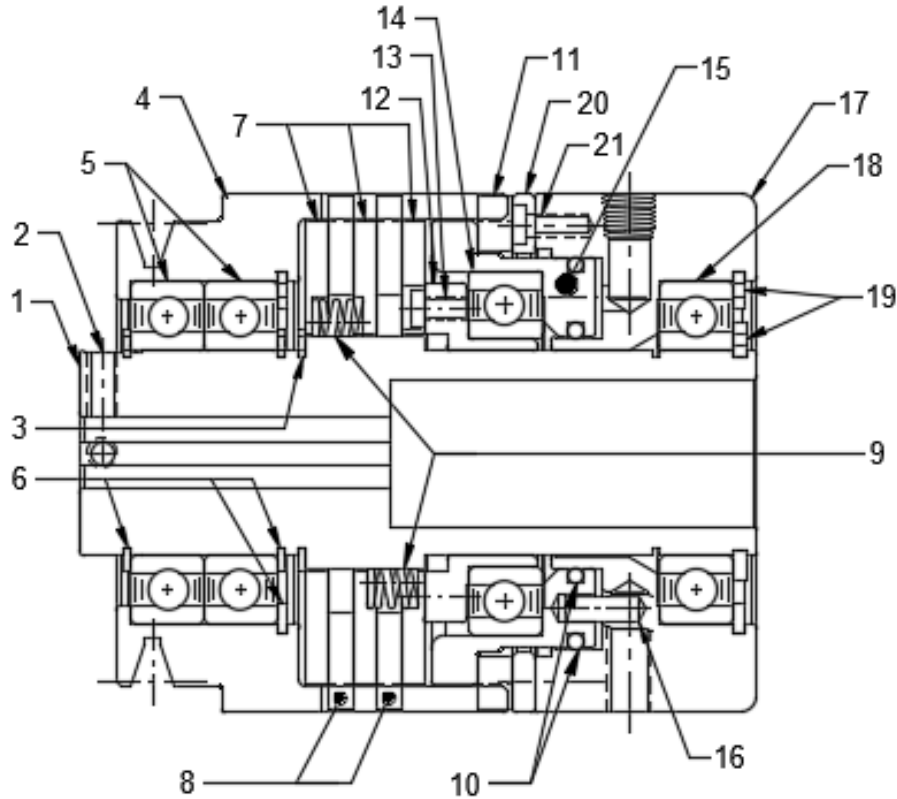

REF#	DESCRIPTION & PARTS INCLUDED	QUANTITY	KIT NUMBER
	DRIVE HUB KIT		W4K2H-002-HUBK
1	Drive Hub	1	
2	Set Screw	2	
3	Retainer Ring	1	
	SLEEVE KIT		W4K2H-001-SLVK
4	Sleeve	1	
5	Bearing	2	
6	Retainer Ring	3	
	DRIVE DISC KIT		W4A2H-STH-DRDK
7	Drive Disc	3	
	REPAIR KIT		W4K2H-002-RPRK
8	Friction Disc	2	
9	Spring	12	
10	O-Ring	2	
11	Brake Friction Disc	1	
	PISTON KIT		W4A2H-STH-PSTK
12	Cone	1	
13	Screw	1	
14	Bearing	1	
15	Piston	1	
	CYLINDER KIT		W4A2H-STH-CYLK
16	Pins	6	
17	Cylinder	1	
18	Bearing	1	
19	Retainer Ring	2	
20	Brake Steel Disc	1	
21	Screw	3	

PARTS KITS

The *Repair Kit* contains common wear items for this product. Users are encouraged to stock one or more repair kits considering the number of units installed and the potential downtime if machinery on which the unit is installed is critical equipment. To obtain current pricing and lead time for parts kits, contact customer service.

orders@machiii.com

ADDITIONAL PRODUCT INFORMATION

For illustrated guides showing how Mach III products work, selection guidelines, product manuals, and installation and use recommendations:

<https://machiii.com/resources/how-our-products-work>

For information about how to order, return policy and warranty information:

<https://machiii.com/resources/how-to-order>



859-291-0849

machiii.com

engineering@machiii.com