



MECHANICAL FRICTION TORQUE LIMITER MECHANISMS with ADAPTER

This document applies to the following catalog standard products,
and to custom versions based upon these models:

[V2R2R-STL](#), [V3R2H-STL](#),

[V4R2H-STL](#), [V5R2H-STL](#)

[V6R1G-STL](#), [V6R2G-STL](#)

[V8R1K-STL](#), [V8R2K-STL](#)

PLEASE NOTE

Mach III products are manufactured on a per order basis and may only be returned in cases of warranty defect. We strongly recommend review of all new applications with Mach III Engineering staff to ensure suitability of the chosen product for the intended use.

© Mach III Clutch, Inc. All Rights Reserved

ADDITIONAL RESOURCES AND SERVICES

PRODUCT DETAIL SHEETS

Click on the product number shown on page 1 of this document for a link to download the product detail sheet which contains dimensional data, torque capacity and other specifications along with parts list and parts kits details. For custom products (part numbers ending in three numeric characters), contact Mach III Engineering.

TECH SUPPORT, 3D MODELS, APPLICATION REVIEW AND SELECTION ASSISTANCE

Mach III Engineering: engineering@machiil.com
859-291-0849

FACTORY REPAIR SERVICE

Clients who want to have a unit evaluated for factory repair service should contact Mach III Customer Service to obtain return materials authorization (RMA). Mach III will evaluate the unit and will issue a quotation if the unit is repairable, or for replacement if the unit is not repairable. Lead time for the repair or replacement will depend upon parts availability and will be included in the quotation.

Mach III Customer Service: orders@machiil.com
859-291-0849

GENERAL SAFETY PRECAUTIONS

WARNING	
	These products include rotating equipment and should be guarded according to OSHA requirements. It is the responsibility of the user to provide the necessary guarding.

WARNING	
	This product can emit a spark and is not recommended for use in any explosive environment.

NEW VERSUS BURNISHED TORQUE

The torque output setting of a friction torque limiter is set at the factory or in the field when new. (All torque settings are +/- 10%.) Repeated overload will burnish the friction surfaces and may increase the slip torque setting. The torque setting should be tested after prolonged or frequent overload and re-set if needed.

PRODUCT SELECTION

Torque capacity is only one factor to consider when making a product selection. Ensure that you will have the right product for the job by contacting our engineering department for application review and selection assistance.

INSTALLATION

1. TORQUE SETTING

Mach III torque limiters are typically shipped to the customer with the torque value they have specified. (Note: All torque settings are +/- 10%.) If a torque limiter requires setting or re-setting in the field, please refer to *TORQUE SETTING INSTRUCTIONS* below.

2. TORQUE LIMITER INSTALLATION

A. SHAFT PREPARATION & MOUNTING

Mach III Clutch products are bored to fit a precision plug gauge for the specified bore size and should slide fit the mating shaft. Make certain that the shaft is free of burrs or nicks. It may be necessary to file or sand the shaft to ensure a slide fit. **Never hammer the torque limiter onto the shaft.** Hammering on the torque limiter may cause evident damage or subtle injury that will shorten the wear life of the unit and will void the warranty.

- (1) Apply the anti-seize (E-Z Break®) lubricant from the packet provided, or equivalent, to the shaft.
- (2) Insert key (customer supplied) onto the shaft.
- (3) Slide clutch over key on the shaft.
- (4) Tighten set screws to secure the clutch to the shaft.

B. FINAL INSPECTION & TESTING

After a short run, check set screws and alignment.

OPERATION

A. INSTALLING ADAPTER

Great care must be taken to ensure proper alignment to prevent premature failure.

Please use the links on page one of this document to obtain the detail sheet for your unit. This sheet will include the pilot diameter and other dimensions needed to machine the component which will be mated to the adapter.

Provide a pilot for clearance (slide fit) for bore in adaptor and drill standard clearance holes for the number and type of screws on the corresponding bolt circle in the mating component. The screws used to attach the component to the adapter should not be any longer than the sum of the depth of the threaded hole in the adapter plus the thickness of the component. Otherwise, the screws may bottom out. Tighten all screws to uniform torque based on screw size and use proper Loctite® (or equivalent) compound to ensure a permanent mount.

B. SPRING PRESSURE

Torque output of this model is proportional to the spring pressure applied. Refer to the Product Detail Sheet for specifics regarding torque capacity.

C. CONTAMINATION

The friction material (pads) contained within this product will absorb oil, water, chemicals, and other contaminants. Depending on the type of contamination, clutch may either seize up entirely or lose torque capacity. If friction discs become contaminated, they should be replaced.

Particulate contamination can also cause premature wear of the drive surfaces and seals. If the operating environment is prone to contamination, a custom, covered unit should be considered. Contact Mach III Engineering to explore options.

MAINTENANCE & REPAIR

When installed and operated according to the preceding guidelines, Mach III Clutch products should require little or no routine maintenance. A repair kit is available which contains all parts subject to typical wear: friction discs, springs and O-rings. The following pages provide instructions for installing a repair kit.

When more extensive repairs are required, contact Mach III Engineering for technical support or Mach III Customer Service for factory rebuild options.

PARTS DIAGRAM

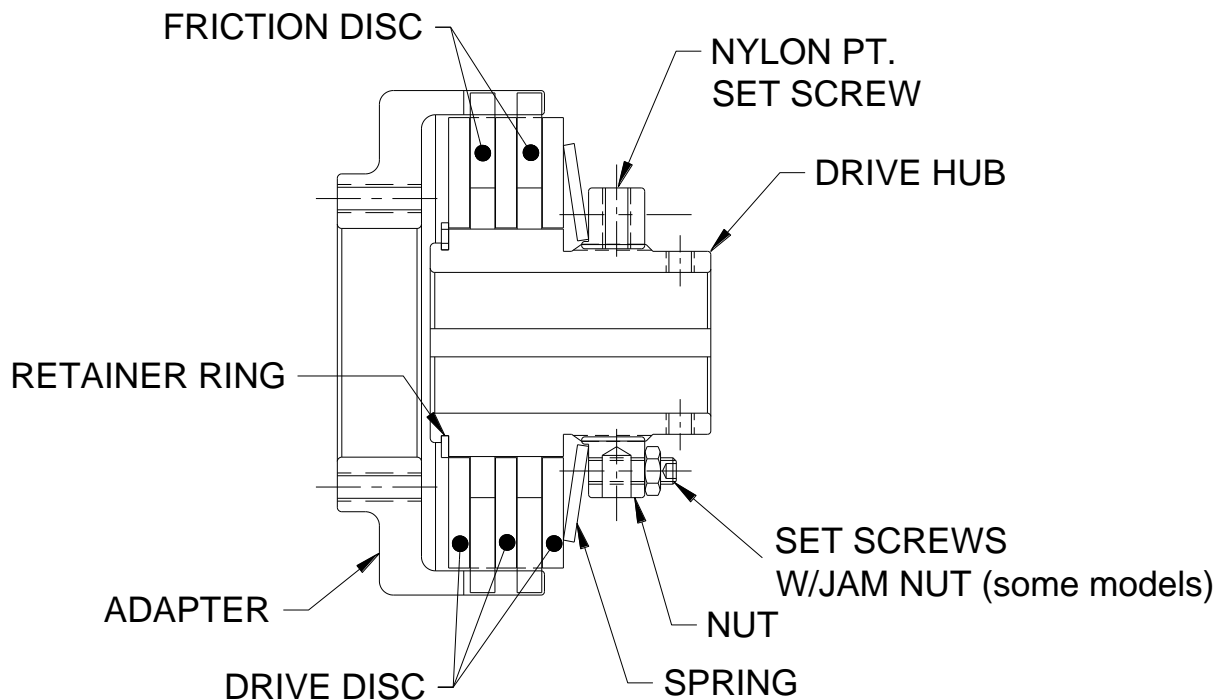

REPAIR KIT INSTALLATION PROCEDURE

TOOLS REQUIRED

Hex Wrench Set
Rubber Mallet or similar soft face hammer
Retainer (snap) Ring Pliers
Scraper

COMPOUNDS REQUIRED

Grease
O-ring Lubricant
Loctite® #609 Retaining Compound
Anti-Seize Lubricant (for re-installation)

A. DISASSEMBLY

1. Remove torque limiter from shaft and place in vertical position with nut end facing upward.
2. Loosen nylon point set screw, set screws and jam nuts (some models) and remove nut. Drive hub will need to be held stationary for this procedure.
3. The disc package (consisting of spring, drive discs and friction discs) will now be accessible.

B. FRICTION DISC & SPRING REPLACEMENT

1. Remove the spring, drive discs and friction discs.
2. Drive discs should be clean, dry and free of burrs or nicks.
3. Reassemble drive & friction disc section according to reference drawing using new spring, drive discs & friction discs as necessary.
4. Ensure that drive discs move freely on the drive hub and that the lugs of the friction disc discs move freely in the drive slots of the sleeve.

C. REASSEMBLY

1. Replace the nut.
2. Adjust to desired torque.
3. Tighten nylon point set screw.
4. *TORQUE LIMITER INSTALLATION* portion of these instructions for the proper procedure for reinstalling the clutch.

TORQUE SETTING INSTRUCTIONS

A. FOR MODELS:

V2R2R-STL, V3R2H-STL, V4R2H-STL, V5R2H-STL

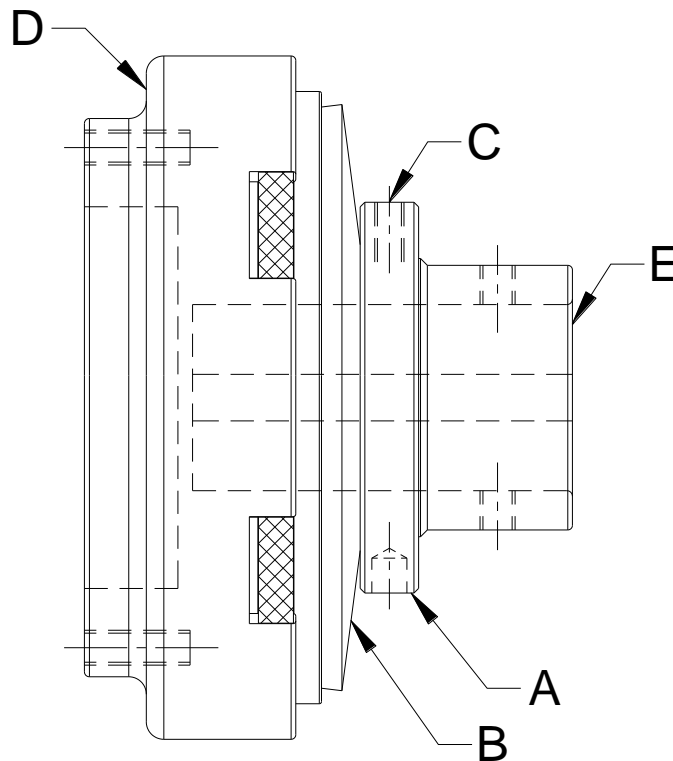

1. Make sure the nylon-tipped set screw (REF. C) in the outside diameter of the adjustment nut (REF. A) is loose.
2. Make sure the adjustment nut (REF. A) is snug against the disc spring (REF. B).
3. Using a spanner wrench, tighten the adjustment nut (REF. A) against the disc spring
4. Check torque value after each 1/4-turn increment of the adjustment nut (REF. A) while holding adapter/sleeve (REF. D) stationary and turning drive hub (REF. E) with a torque wrench.
5. Tighten the nylon-tipped set screw (REF. C) in the outside diameter of the adjustment nut (REF. A).

B. FOR MODELS:

V6R1G-STL, V6R2G-STL, V8R1K-STL, V8R2K-STL

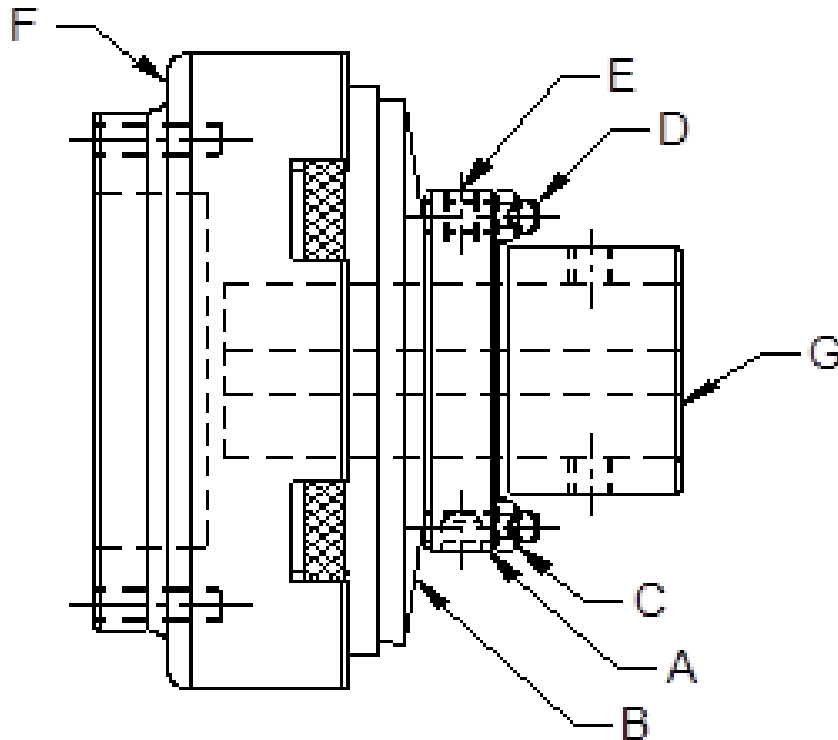

1. Make sure the adjustment nut (REF. A) is snug against the disc spring (REF. B).
2. Make sure the six jam nuts (REF. C) mounted on the six set screws (REF. D) which are placed axially in adjustment nut (REF. A) are loose.
3. Screw the six set screws (REF. D) in the adjustment nut (REF. A) until they contact the disc spring (REF. B).
4. Using a circular pattern, tighten the six set screws (REF. D) in the adjustment nut (REF. A) one 1/4-turn each.

NOTE: If needed, fine tune the torque value of the unit in 1/8-turn increments of the six set screws (REF. D).

5. Check torque value after each 1/4-turn increment of all six set screws (REF. D) while holding adapter/sleeve (REF. F) stationary and turning drive hub (REF. G) with a torque wrench.

NOTE: A torque wrench with a multiplier may be needed for higher torque settings.

6. Once desired torque is reached, confirm each of the six set screws (REF. D) are in contact with the disc spring (REF. B).
7. Tighten the jam nuts (REF. C) mounted on the six set screws (REF. D) firmly against the adjustment nut (REF. A).
8. Tighten the nylon-tipped set screw (REF. E) in the outside diameter of the adjustment nut (REF. A).

MACH III PRODUCT WARRANTY

Mach III Clutch, Inc. warrants its products to be free from defects in materials and workmanship for a period of one year from the date of shipment from our factory or from the location of one of our authorized distributors provided the product is properly installed, maintained and has been operated under normal conditions. This warranty shall not apply to products that have been subject to misuse, negligence or accident, or damaged by circumstances beyond the control of Mach III Clutch, Inc., or which has been used in a manner contrary to Mach III Clutch, Inc.'s instructions or recommendations. Products that have been altered after shipment or repaired without following proper repair procedures, as deemed by Mach III Clutch, Inc., are also expressly excluded from this warranty.

Warranty claims shall be made in writing and the product(s) shall, if requested by Mach III Clutch, Inc., be returned with transportation charges prepaid for evaluation. Upon our determination that a defect exists, Mach III Clutch, Inc., at its sole discretion, will either repair or replace the defective component(s) or product(s).

THIS WARRANTY IS MADE EXPRESSLY IN LIEU OF ANY OTHER WARRANTIES, EXPRESS OR IMPLIED, INCLUDING ANY IMPLIED WARRANTY OF MERCHANTABILITY OR FITNESS FOR A PARTICULAR PURPOSE. THE BUYER'S SOLE AND EXCLUSIVE REMEDY SHALL BE FOR THE REPAIR OR REPLACEMENT OF DEFECTIVE PRODUCTS AS PROVIDED HEREIN AND UNDER NO CIRCUMSTANCES WILL MACH III CLUTCH, INC.'S LIABILITY EXCEED THE PRICE OF THE DEFECTIVE UNITS. THE BUYER AGREES THAT NO OTHER REMEDY (INCLUDING, BUT NOT LIMITED TO, INCIDENTAL OR CONSEQUENTIAL DAMAGES FOR LOST PROFITS, LOST SALES, INJURY TO PERSON OR PROPERTY OR ANY OTHER INCIDENTAL OR CONSEQUENTIAL LOSS) SHALL BE AVAILABLE TO HIM OR HER.

Mach III Clutch, Inc. neither assumes nor authorizes any person to assume for it any other liability in connection with the sale of its products.



Mach III Clutch
1580 Lake Street
Elmira, NY 14901 USA
www.machiii.com
(859) 291-0849