

# T4A1H-001

Mechanical Friction Torque Limiter with Pulley and Shrink Disc



Designed for brief overloads.  
Does not automatically disconnect.

### Engagement/Disengagement

Spring/None

### Facing Type

Low Coefficient

### Minimum Torque Setting

70 Pound Inches

### Maximum Torque Setting (Spring Compression ≈ 27%)

703 Pound Inches

### Maximum RPM

1,750

### Bore without Keyway

1.125

### Finish

Aluminum

### Open or Enclosed Construction

Open

### Shipping Weight

7 Pounds

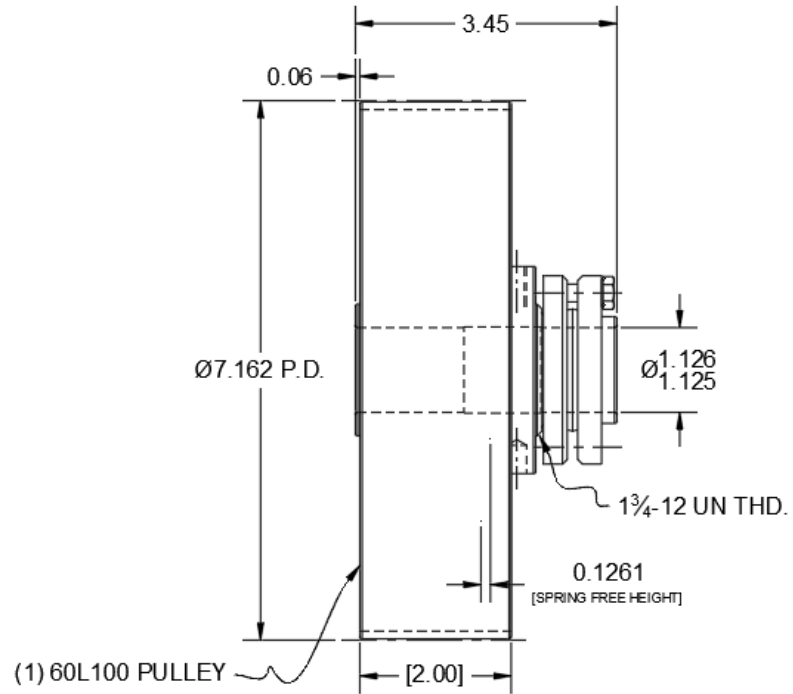

### TORQUE vs. SPRING PRESSURE

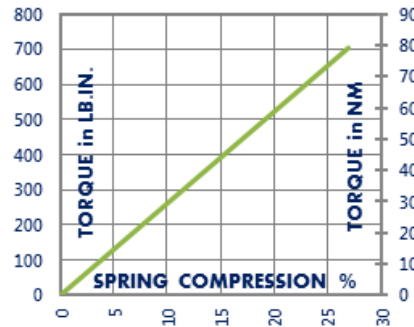

### NEW vs. BURNISHED TORQUE

The torque output setting of a friction torque limiter is set at the factory or in the field when new. (All torque settings are +/- 10%.) Repeated overload will burnish the friction surfaces and may increase the slip torque setting. The torque setting should be tested after prolonged or frequent overload and reset if needed.

### PRODUCT SELECTION

Torque capacity is only one factor to consider when making a product selection. Ensure that you will have the right product for the job by contacting our engineering department for application review and selection assistance.



101 Cummings Drive  
Walton, KY 41094 USA

859-291-0849  
machiii.com

engineering@machiii.com

# T4A1H-001

## Parts Diagram

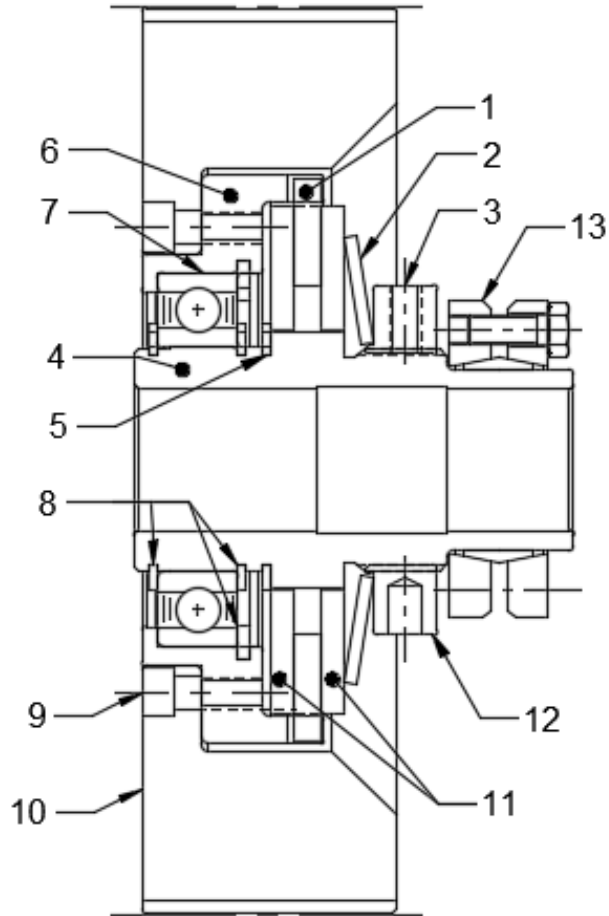

REF#	DESCRIPTION & PARTS INCLUDED	QUANTITY	KIT NUMBER
	<b>REPAIR KIT</b>		<b>T4A1H-001-RPRK</b>
1	Friction Disc	1	
2	Disc Spring	1	
3	Nylon Point Set Screw	1	
	<b>DRIVE HUB KIT</b>		<b>T4A1H-001-HUBK</b>
4	Drive Hub	1	
5	Retainer Ring	1	
	<b>SLEEVE KIT</b>		<b>T4A1H-001-SLVK</b>
6	Sleeve	1	
7	Bearing	1	
8	Retainer Ring	3	
	<b>PULLEY KIT</b>		<b>T4A1H-001-PULK</b>
9	Screw	6	
10	Pulley	1	
	<b>DRIVE DISC KIT</b>		<b>T4A1H-001-DRDK</b>
11	Drive Disc	2	
	<b>FACING KIT</b>		<b>T4A1H-001-FCGK</b>
1	Friction Disc	1	
3	Nylon Point Set Screw	1	
	<b>NUT KIT</b>		<b>T4A2H-STL-NUTK</b>
3	Nylon Point Set Screw	1	
12	Nut	1	
	<b>CLAMP COLLAR KIT</b>		<b>T4A1H-001-CLCK</b>
13	Clamp Collar	1	

### PARTS KITS

The *Repair Kit* contains common wear items for this product. Users are encouraged to stock one or more repair kits considering the number of units installed and the potential downtime if machinery on which the unit is installed is critical equipment. To obtain current pricing and lead time for parts kits, contact customer service.

[orders@machiii.com](mailto:orders@machiii.com)

### ADDITIONAL PRODUCT INFORMATION

For illustrated guides showing how Mach III products work, selection guidelines, product manuals, and installation and use recommendations:

<https://machiii.com/resources/how-our-products-work>

For information about how to order, return policy and warranty information:

<https://machiii.com/resources/how-to-order>



859-291-0849

[machiii.com](http://machiii.com)

[engineering@machiii.com](mailto:engineering@machiii.com)