



SensiFlex[®]

SHAFT INPUT TENSION CONTROL CLUTCH

Patent No. 6,578,691 B1

This document applies to the following catalog standard products,
and to custom versions based upon these models:

[38SI & 38SI-ULOW](#)

[58SI & 58SI-ULOW](#)

[78SI & 78SI-ULOW](#)

[98SI & 98SI-ULOW](#)

[118SI & 118SI-ULOW](#)

PLEASE NOTE

Mach III products are manufactured on a per order basis and may only be returned in cases of warranty defect. We strongly recommend review of all new applications with Mach III Engineering staff to ensure suitability of the chosen product for the intended use.

© Mach III Clutch, Inc. All Rights Reserved

ADDITIONAL RESOURCES AND SERVICES

PRODUCT DETAIL SHEETS

Click on the product number shown on page 1 of this document for a link to download the product detail sheet which contains dimensional data, torque capacity and other specifications along with parts list and parts kits details. For custom products (part numbers ending in three numeric characters), contact Mach III Engineering.

ANTI-ROTATION ARM MOUNTING INSTRUCTIONS

Mach III through-shaft mounted clutches and clutch-brake combinations require installation of an anti-rotation arm (also known as a reaction arm) which is discussed later in this manual. Recommendations are illustrated in the following document:

<http://machiii.com/pdfs/Anti-Rotation-Arm-Mounting-Instructions.pdf>

TECH SUPPORT, 3D MODELS, APPLICATION REVIEW AND SELECTION ASSISTANCE

Mach III Engineering: engineering@machiii.com
859-291-0849

FACTORY REPAIR SERVICE

Clients who want to have a unit evaluated for factory repair service should contact Mach III Customer Service to obtain return materials authorization (RMA). Mach III will evaluate the unit and will issue a quotation if the unit is repairable, or for replacement if the unit is not repairable. Lead time for the repair or replacement will depend upon parts availability and will be included in the quotation.

Mach III Customer Service: orders@machiii.com
859-291-0849

GENERAL SAFETY PRECAUTIONS

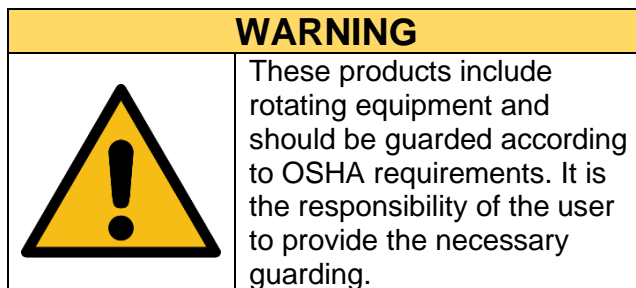

NEW VERSUS BURNISHED TORQUE

The torque output of a new friction clutch or brake can be up to 40% less than the published torque rating. To achieve full design torque, a unit must be cycled under load to burnish the friction surfaces. The exact number of cycles varies by application. When calculating required torque always use a safety factor of 1.5 to 2. It is not recommended to select a product for use at its maximum rated torque for continuous duty.

PRODUCT SELECTION

Torque capacity is only one factor to consider when making a product selection. Ensure that you will have the right product for the job by contacting our engineering department for application review and selection assistance.

INSTALLATION

1. INSTALLING A SPROCKET OR PULLEY

Mach III units are typically shipped from the factory with the required sprocket or pulley preinstalled. This section pertains only to those who need to install or replace a pulley or sprocket in the field. Please use the links on page one of this document to obtain the detail sheet for your unit. This sheet will include the pilot diameter and other dimensions needed to machine the sprocket or pulley.

Bore the sprocket or pulley for clearance (slide fit) over pilot and drill standard clearance holes for the number and type of screws on corresponding bolt circle. The cap screws used to attach the sprocket or pulley should not be longer than the sum of the depth of the threaded hole plus the thickness of the sprocket or pulley. Otherwise, the cap screws may bottom out. Tighten all screws to uniform torque based on screw size and use proper Loctite® (or equivalent) compound to ensure a permanent mount.

2. CLUTCH INSTALLATION

A. SHAFT PREPARATION & MOUNTING

Mach III Clutch products are bored to fit a precision plug gauge for the specified bore size and should slide fit the mating shaft. Make certain that the shaft is free of burrs or nicks. It may be necessary to file or sand the shaft to ensure a slide fit. **Never hammer the clutch onto the shaft.** Hammering on the clutch may cause evident damage or subtle injury that will shorten the wear life of the unit and will void the warranty.

- (1) Apply the anti-seize (E-Z Break®) lubricant from the packet provided, or equivalent, to the shaft.
- (2) Insert key (customer supplied) onto the shaft.
- (3) Slide clutch over key on the shaft, align the sprocket or pulley.
- (4) Tighten set screws to secure the clutch to the shaft.

B. AIR LINE CONNECTION

Refer to the Product Detail Sheet to determine the NPT or BSPT size and connect an air fitting of the applicable size. Install the fitting using a thread sealing compound to prevent air leakage. **Do not use rigid piping.** Flexible air line should always be used.

C. AIR SUPPLY

Mach III products require clean, filtered, pressure regulated air. Air lubricators are neither required nor recommended as all bearings, bushings and seals are lubricated for life upon assembly.

D. ANTI-ROTATION (REACTION) ARM CONNECTION

The air cylinder portion of a Mach III through shaft style clutch is designed to remain stationary. Due to friction in the bearing housed in the air cylinder, this member will rotate unless an anti-rotation arm (a.k.a. reaction arm) is installed. A threaded hole is provided in the cylinder for the installation of this arm. **Note that in all cases, the machine frame or bracket should not be tight against the housing of the clutch as contact may impede piston movement and will shorten bearing life.**

Refer to the [Anti-Rotation Arm Installation Instructions](#) document for detailed recommendations.

E. FINAL INSPECTION & TESTING

Check alignment of the sprocket or pulley. Cycle the clutch with the machine off to check for air leaks and to ensure proper engagement and release. After a short run, check set screws and alignment.

OPERATION

A. AIR PRESSURE

Torque output of this model is proportional to air pressure applied. Refer to the Product Detail Sheet for specifics regarding torque capacity. The air pressure supplied to the unit should be regulated to the minimum amount necessary to attain the required torque output. **The maximum operating pressure should not exceed 80 PSI.** SensiFlex® clutches are designed for use in slip applications, typically to maintain tension on a web during rewinding or a similar tension control application. Mach III Clutch, Inc. should always be consulted to assist with selection of a SensiFlex® Clutch to ensure that the required tension can be maintained while dissipating the heat caused by constant slip.

B. CONTAMINATION

The friction material (pads) contained within this product will absorb oil, water, chemicals, and other contaminants. Depending on the type of contamination, clutch may either seize up entirely or lose torque capacity. If friction discs become contaminated, they should be replaced.

Particulate contamination can also cause premature wear of the drive surfaces and seals. If the operating environment is prone to contamination, a custom, covered unit should be considered. Contact Mach III Engineering to explore options.

MAINTENANCE & REPAIR

When installed and operated according to the preceding guidelines, Mach III Clutch products should require little or no routine maintenance. A repair kit is available which contains all parts subject to typical wear: friction discs, springs, and O-rings. The following pages provide instructions for installing a repair kit.

When more extensive repairs are required, contact Mach III Engineering for technical support or Mach III Customer Service for factory rebuild options.

PARTS DIAGRAM

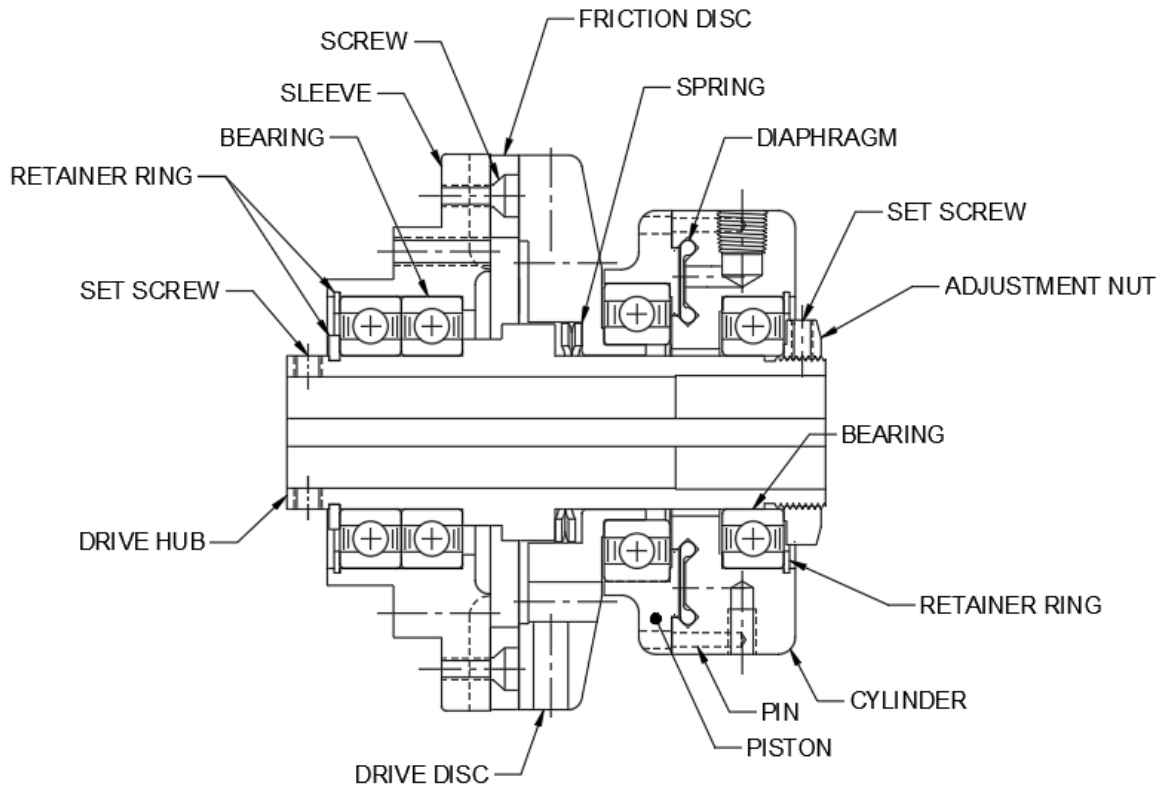

REPAIR KIT INSTALLATION PROCEDURE

TOOLS REQUIRED

Hex Wrench Set
Rubber Mallet or similar soft face hammer
Retainer (snap) Ring Pliers
Scraper

COMPOUNDS REQUIRED

Grease
O-ring Lubricant
Loctite® #609 Retaining Compound
Anti-Seize Lubricant (for re-installation)

A. DISASSEMBLY

- (1) Loosen set screws using appropriate hex wrench and slide the clutch off of the shaft. Place the clutch on a work surface with the air cylinder end of the clutch upward.
- (2) Loosen the set screw in the adjustment nut and remove nut using a wrench or channel lock pliers. The air cylinder bearing is a slide fit on the drive hub and is affixed to the drive hub with a thin coating of Loctite®. You may need to strike the hub, or an object inserted in the hub with a rubber mallet or similar soft face hammer, while pulling the cylinder upwards to break the Loctite® seal.

B. DRIVE SURFACE INSPECTION

Inspect the drive surface of the cast iron sleeve input member. Grooves in the surface would indicate that the friction disc should have been replaced sooner and the heads of the mounting screws have made contact. This surface must be free from grooves, burrs and foreign materials in order for the clutch to operate properly. If damage is pronounced, please contact Mach III Clutch or your distributor about replacing the sleeve and procedure. In addition, clutch should be inspected for discoloration (turning blue). If discoloration is present, the unit is being operated beyond its capacity and Mach III Clutch should be contacted for assistance.

C. FRICTION DISC REPLACEMENT

- (1) Remove brass screws and friction disc.
- (2) Inspect the friction disc mounting surface making sure that it is smooth and free from contamination.
- (3) Mount new friction disc and firmly tighten screws using an alternating sequence.

D. DIAPHRAGM INSPECTION & REPLACEMENT

Diaphragm replacement should rarely be necessary if the air supply is regulated and free of contamination and if the gap between the friction and drive disc is properly set.

- (1) Separate the air cylinder and piston by pulling apart taking care not to bend pins.
- (2) Pinch the diaphragm and pull from the grooves which retain it. Make sure that the retaining grooves and surface underneath the diaphragm are clean & free from debris.
- (3) Lubricate the new diaphragm (if replacement is necessary) with an O-ring lubricant such as Dow Corning® #4.
- (4) Install with the lips located on the ID and OD of the diaphragm facing downward. Press the lips into the grooves by applying pressure while gliding a finger along each perimeter of the diaphragm. Ensure that the lips are fully seated by running your thumb across the surface of the diaphragm in a clockwise motion several times.

E. REASSEMBLY

- (1) Apply a thin coat of grease (such as Molykote® G-N Metal Assembly Paste) to the hex drive surface of the drive hub. Be sure the spring is in place over drive hub and surrounding the hex portion of the hub. Place piston/drive disc assembly over drive hub. Drive disc assembly should move freely over hex.
- (2) Place cylinder assembly over hub. Align pins in the holes in the piston and manually press the cylinder downward to reconnect with piston.
- (3) Place the adjustment nut on the threads and tighten to a point where a 0.010 - 0.020 gap remains between friction disc and sleeve. It is recommended that a feeler gauge be used.
- (4) Tighten set screw in adjustment nut.
- (5) See *Clutch Installation* section of this document for the proper re-installation procedure.

MACH III PRODUCT WARRANTY

Mach III Clutch, Inc. warrants its products to be free from defects in materials and workmanship for a period of one year from the date of shipment from our factory or from the location of one of our authorized distributors provided the product is properly installed, maintained and has been operated under normal conditions. This warranty shall not apply to products that have been subject to misuse, negligence or accident, or damaged by circumstances beyond the control of Mach III Clutch, Inc., or which has been used in a manner contrary to Mach III Clutch, Inc.'s instructions or recommendations. Products that have been altered after shipment or repaired without following proper repair procedures, as deemed by Mach III Clutch, Inc., are also expressly excluded from this warranty.

Warranty claims shall be made in writing and the product(s) shall, if requested by Mach III Clutch, Inc., be returned with transportation charges prepaid for evaluation. Upon our determination that a defect exists, Mach III Clutch, Inc., at its sole discretion, will either repair or replace the defective component(s) or product(s).

THIS WARRANTY IS MADE EXPRESSLY IN LIEU OF ANY OTHER WARRANTIES, EXPRESS OR IMPLIED, INCLUDING ANY IMPLIED WARRANTY OF MERCHANTABILITY OR FITNESS FOR A PARTICULAR PURPOSE. THE BUYER'S SOLE AND EXCLUSIVE REMEDY SHALL BE FOR THE REPAIR OR REPLACEMENT OF DEFECTIVE PRODUCTS AS PROVIDED HEREIN AND UNDER NO CIRCUMSTANCES WILL MACH III CLUTCH, INC.'S LIABILITY EXCEED THE PRICE OF THE DEFECTIVE UNITS. THE BUYER AGREES THAT NO OTHER REMEDY (INCLUDING, BUT NOT LIMITED TO, INCIDENTAL OR CONSEQUENTIAL DAMAGES FOR LOST PROFITS, LOST SALES, INJURY TO PERSON OR PROPERTY OR ANY OTHER INCIDENTAL OR CONSEQUENTIAL LOSS) SHALL BE AVAILABLE TO HIM OR HER.

Mach III Clutch, Inc. neither assumes nor authorizes any person to assume for it any other liability in connection with the sale of its products.



Mach III Clutch
1580 Lake Street
Elmira, NY 14901 USA
www.machiii.com
(859) 291-0849