

C4D2R-009

Covered Air Engaged Friction Clutch with Pulley



Engagement/Disengagement

Air/Spring

Facing Type

High Coefficient

Torque @ 80 PSI – Dynamic

1,317 Pound Inches

Minimum Engagement Pressure

4 PSI

Maximum Operating Pressure

80 PSI

Maximum RPM

1,500

Bore with Standard Keyway

1.125

Air Volume New

0.42 Cubic Inches

Air Volume Worn

3.23 Cubic Inches

Finish

Aluminum

Open or Enclosed Construction

Enclosed

Shipping Weight

11 Pounds

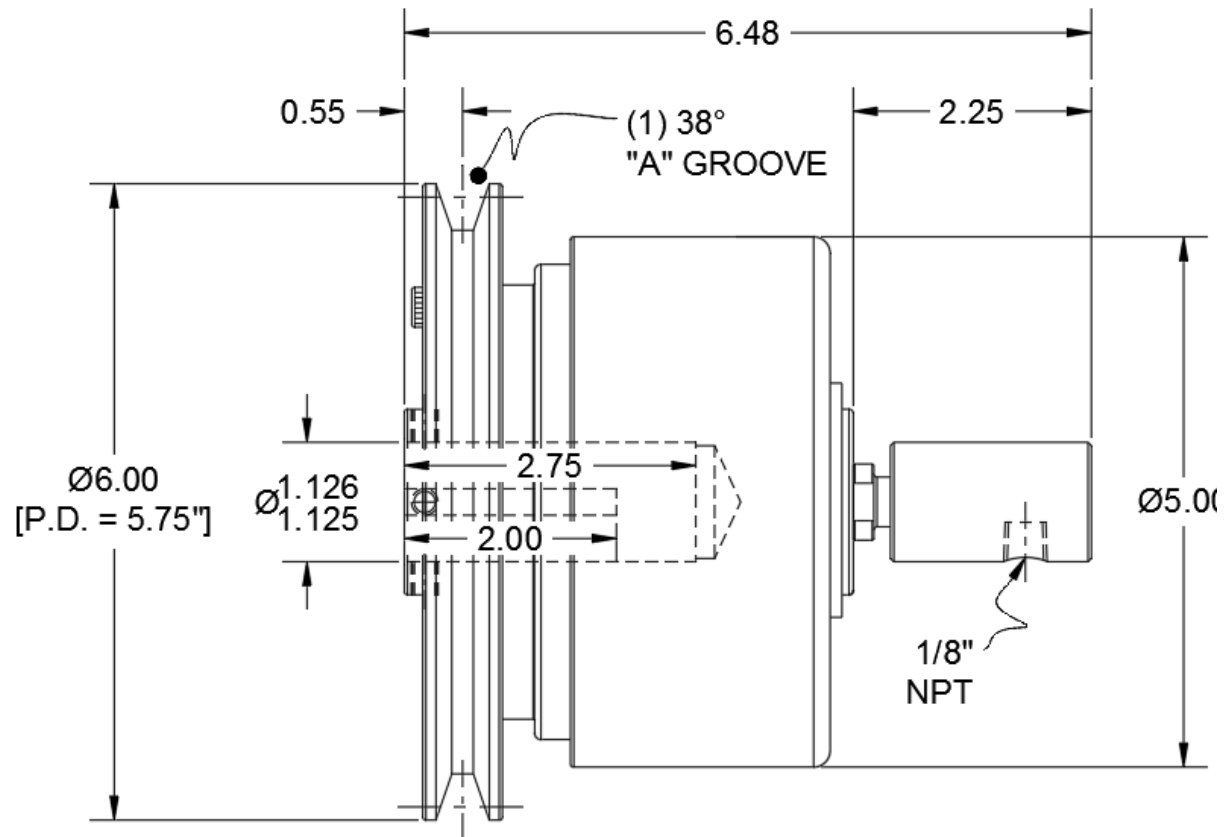

TORQUE vs. AIR PRESSURE

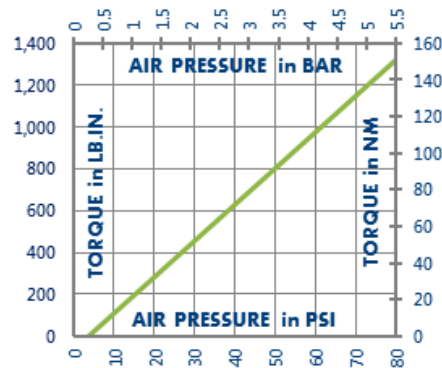

NEW vs. BURNISHED TORQUE

The torque output of a new friction brake or clutch can be up to 40% less than the published torque rating. To achieve full design torque, a unit must be cycled under load to burnish the friction surfaces. The exact number of cycles varies by application.

When calculating required torque always use a safety factor of 1.5 to 2. It is not recommended to select a product for use at its maximum rated torque for continuous duty.

PRODUCT SELECTION

Torque capacity is only one factor to consider when making a product selection. Ensure that you will have the right product for the job by contacting our engineering department for application review and selection assistance.



101 Cummings Drive
Walton, KY 41094 USA

859-291-0849

machiii.com

engineering@machiii.com

C4D2R-009

Parts Diagram

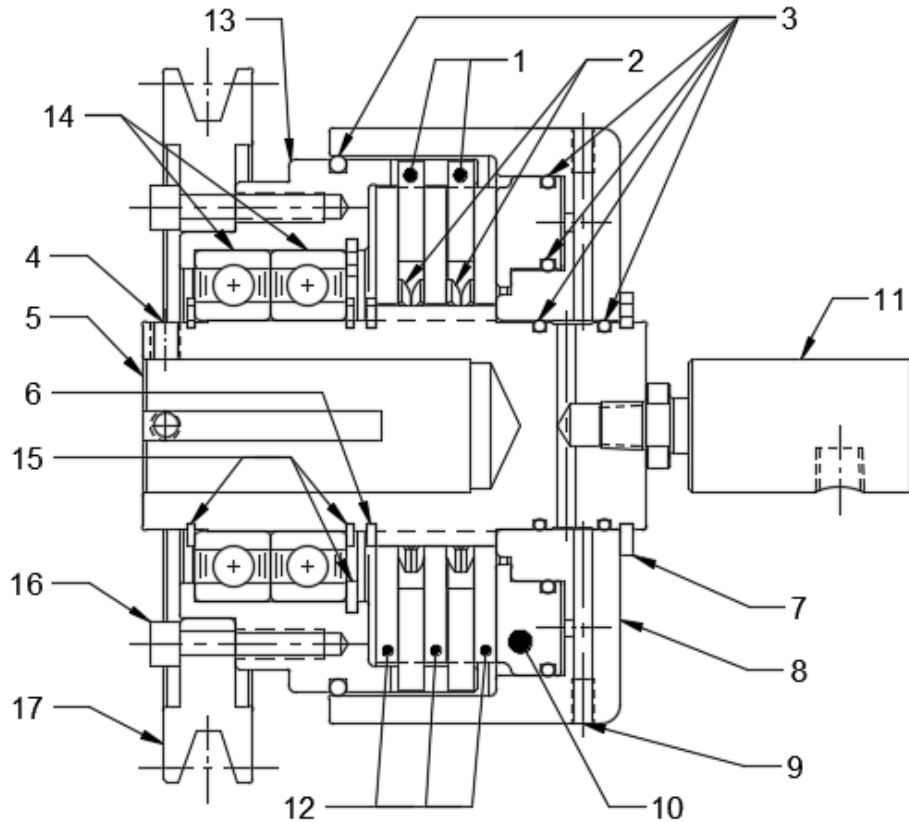

REF#	DESCRIPTION & PARTS INCLUDED	QUANTITY	KIT NUMBER
	REPAIR KIT		C4D2R-009-RPRK
1	Friction Disc	2	
2	Wave Spring	2	
3	O-Ring	5	
	DRIVE HUB KIT		C4D2R-009-HUBK
4	Set Screw	2	
5	Drive Hub	1	
6	Retainer Ring	1	
	CYLINDER KIT		C4D2R-009-CYLK
7	Retainer Ring	1	
8	Cylinder	1	
9	Screw	2	
10	PISTON	1	C4D2H-STH-P004
11	ROTATING SEAL	1	RSEAL-032
	DRIVE DISC KIT		C4D2R-STH-DRDK
12	Drive Disc	3	
	SLEEVE KIT		C4D2R-009-SLVK
13	Sleeve	1	
14	Bearing	2	
15	Retainer Ring	3	
	PULLEY KIT		C4D2R-009-PULK
16	Screw	6	
17	Pulley	1	

PARTS KITS

The *Repair Kit* contains common wear items for this product. Users are encouraged to stock one or more repair kits considering the number of units installed and the potential downtime if machinery on which the unit is installed is critical equipment. To obtain current pricing and lead time for parts kits, contact customer service.

orders@machiii.com

ADDITIONAL PRODUCT INFORMATION

For illustrated guides showing how Mach III products work, selection guidelines, product manuals, and installation and use recommendations:

<https://machiii.com/resources/how-our-products-work>

For information about how to order, return policy and warranty information:

<https://machiii.com/resources/how-to-order>



859-291-0849

machiii.com

engineering@machiii.com