



SPRING ENGAGED FRICTION BRAKES NEMA FRAME MOUNT

This document applies to the following catalog standard products,
and to custom versions based upon these models:

[D3C2F-34H](#), [D3C2F-34HCA](#) & [D3C2F-34HSS](#)

[D3C3R-56H](#), [D3C3R-56HCA](#) & [D3C3R-56HSS](#)

[D3C3R-14H](#), [D3C3R-14HCA](#) & [D3C3R-14HSS](#)

[D5C3R-18H](#), [D5C3R-18HCA](#) & [D5C3R-18HSS](#)

[D5C3R-21H](#), [D5C3R-21HCA](#) & [D5C3R-21HSS](#)

[D8C2K-28H](#), [D8C2K-28HCA](#) & [D8C2K-28HSS](#)

PLEASE NOTE

Mach III products are manufactured on a per order basis and may only be returned in cases of warranty defect. We strongly recommend review of all new applications with Mach III Engineering staff to ensure suitability of the chosen product for the intended use.

ADDITIONAL RESOURCES AND SERVICES

PRODUCT DETAIL SHEETS

Click on the product number shown on page 1 of this document for a link to download the product detail sheet which contains dimensional data, torque capacity and other specifications along with parts list and parts kits details. For custom products (part numbers ending in three numeric characters), contact Mach III Engineering.

TECH SUPPORT, 3D MODELS, APPLICATION REVIEW AND SELECTION ASSISTANCE

Mach III Engineering: engineering@machiii.com
859-291-0849

FACTORY REPAIR SERVICE

Clients who want to have a unit evaluated for factory repair service should contact Mach III Customer Service to obtain return materials authorization (RMA). Mach III will evaluate the unit and will issue a quotation if the unit is repairable, or for replacement if the unit is not repairable. Lead time for the repair or replacement will depend upon parts availability and will be included in the quotation.

Mach III Customer Service: orders@machiii.com
859-291-0849

GENERAL SAFETY PRECAUTIONS

WARNING	
	These products include rotating equipment and should be guarded according to OSHA requirements. It is the responsibility of the user to provide the necessary guarding.

WARNING	
	This product can emit a spark and is not recommended for use in any explosive environment.

NEW VERSUS BURNISHED TORQUE

The torque output of a new friction clutch or brake can be up to 40% less than the published torque rating. To achieve full design torque, a unit must be cycled under load to burnish the friction surfaces. The exact number of cycles varies by application. When calculating required torque always use a safety factor of 1.5 to 2. It is not recommended to select a product for use at its maximum rated torque for continuous duty.

PRODUCT SELECTION

Torque capacity is only one factor to consider when making a product selection. Ensure that you will have the right product for the job by contacting our engineering department for application review and selection assistance.

INSTALLATION

1. BRAKE INSTALLATION

A. SHAFT PREPARATION & MOUNTING

Mach III Clutch products are bored to fit a precision plug gauge for the specified bore size and should slide fit the mating shaft. Make certain that the shaft is free of burrs or nicks. It may be necessary to file or sand the shaft to ensure a slide fit. **Never hammer the brake onto the shaft.** Hammering on the brake may cause evident damage or subtle injury that will shorten the wear life of the unit and will void the warranty.

- (1) Apply the anti-seize (E-Z Break[®]) lubricant from the packet provided, or equivalent, to the shaft.
- (2) Insert key (customer supplied) onto the shaft.
- (3) Slide brake over key on the shaft.

B. MOUNTING

The brake mounts between a motor and gear reducer. These units are not suitable for belt drive (pulley output) applications. Consult factory for options.

C. AIR LINE CONNECTION

Refer to the Product Detail Sheet to determine the NPT or BSPT size and connect an air fitting of the applicable size. Install the fitting using a thread sealing compound to prevent air leakage. **Do not use rigid piping.** Flexible air line should always be used.

D. AIR SUPPLY

Mach III products require clean, filtered, pressure regulated air. Air lubricators are neither required nor recommended as all bearings, bushings and seals are lubricated for life upon assembly.

E. FINAL INSPECTION & TESTING

Cycle the brake with the machine off to check for air leaks and to ensure proper engagement and release. After a short run, check set screws and mounting screws.

OPERATION

A. AIR PRESSURE

This brake is spring engaged (air released). The air pressure to release the brake is between 60 and 70 psi. **For maximum life of the brake, operating pressure should not exceed 80 PSI.**

B. CONTAMINATION

The friction material (pads) contained within this product will absorb oil, water, chemicals, and other contaminants. Depending on the type of contamination, clutch may either seize up entirely or lose torque capacity. If friction discs become contaminated, they should be replaced.

Particulate contamination can also cause premature wear of the drive surfaces and seals. If the operating environment is prone to contamination, a custom, covered unit should be considered. Contact Mach III Engineering to explore options.

MAINTENANCE & REPAIR

When installed and operated according to the preceding guidelines, Mach III Clutch products should require little or no routine maintenance. A repair kit is available which contains all parts subject to typical wear: friction discs, springs and O-rings. The following pages provide instructions for installing a repair kit.

When more extensive repairs are required, contact Mach III Engineering for technical support or Mach III Customer Service for factory rebuild options.

PARTS DIAGRAM:

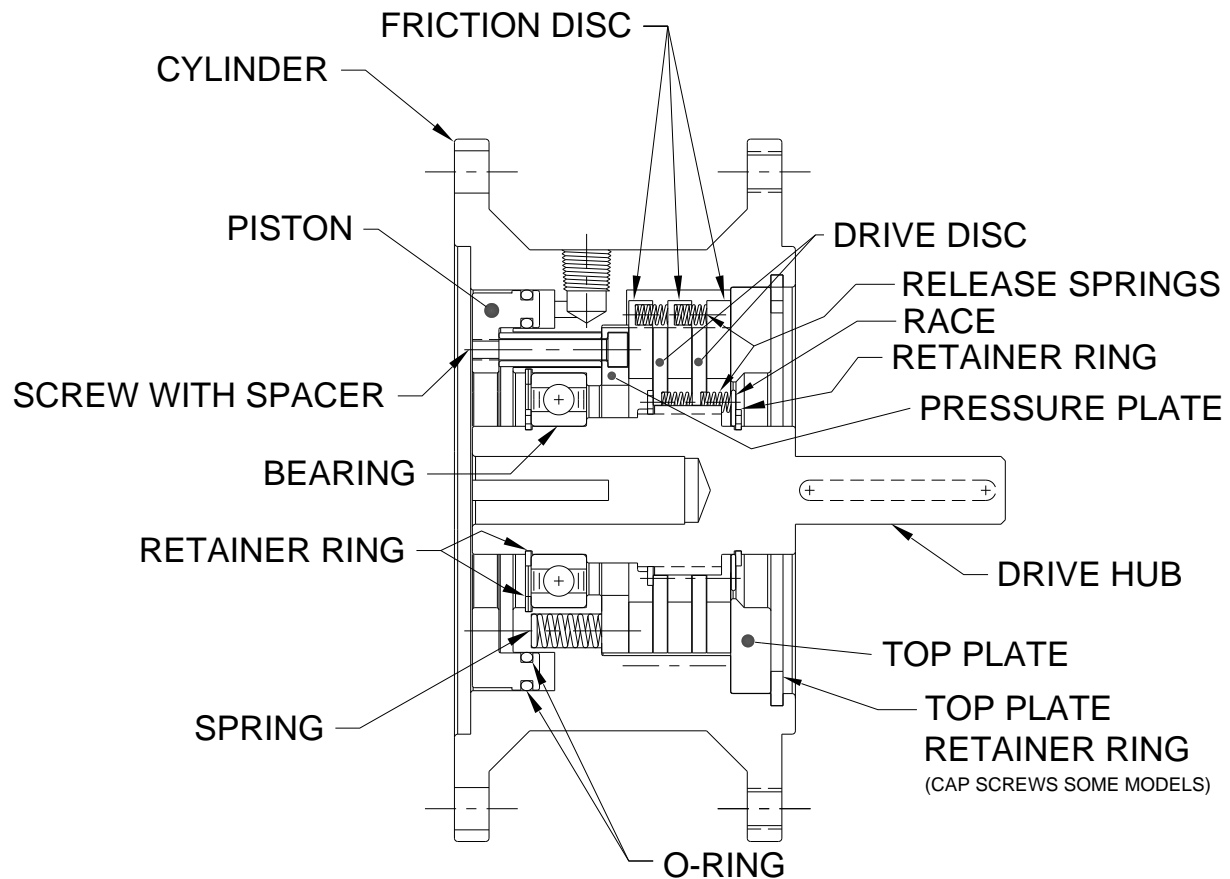

REPAIR KIT INSTALLATION PROCEDURE

TOOLS REQUIRED

Hex Wrench Set
Rubber Mallet or similar soft face hammer
Retainer (snap) Ring Pliers
Scraper

COMPOUNDS REQUIRED

Grease
O-ring Lubricant
Loctite® #609 Retaining Compound
Anti-Seize Lubricant (for re-installation)

A. COMPLETE DISASSEMBLY

- (1) Remove brake from shaft and place in vertical position with top plate end facing upward.
- (2) Apply air to brake to relieve spring pressure from top plate.
- (3) Remove top plate retainer ring or cap screws and top plate.
- (4) Remove retainer ring, race and springs.
- (5) Remove drive discs, friction discs and remaining springs.
- (6) Remove air supply from brake.
- (7) Invert brake and remove retainer ring from drive hub.
- (8) Remove air cylinder with bearing from drive hub. The air cylinder bearing is a slide fit on the drive hub and is affixed to the drive hub with a thin coating of Loctite®. You may need to strike the hub, or an object inserted in the hub with a rubber mallet or similar soft face hammer to break the Loctite® seal.
- (9) Next, remove the screws from pressure plate.
- (10) Remove spacers and springs.
- (11) Separate piston from cylinder.

B. FRICTION DISC REPLACEMENT ONLY

- (1) Remove brake from shaft and place in vertical position with top plate end facing upward.
- (2) Apply air to brake to relieve spring pressure from top plate.
- (3) Remove top plate retainer ring or cap screws and top plate.
- (4) Remove retainer ring, race and springs.
- (5) Remove drive discs, friction discs and remaining springs.
- (6) Drive discs should be clean, dry and free of burrs or nicks.
- (7) Reassemble drive disc, friction disc, springs and race section according to reference drawing using new friction discs, drive discs and springs as necessary.

Alignment of Wave Springs

The beginning of the coil of each wave spring should be placed in the same relative (o'clock) position to the drive hub to ensure equal separation of the drive discs.

Seating of Coil Springs

Coil springs must be flatly seated in the milled holes of the drive discs and friction discs.

- (8) Ensure that drive discs move freely on the drive hub and that the friction discs move freely in the cylinder or ring gear.

C. O-RING REPLACEMENT

- (1) Follow COMPLETE DISASSEMBLY instructions above.
- (2) Separate cylinder and piston.
- (3) Inspect O-ring seals. If worn, replace using new O-rings that have been lubricated with an O-ring lubricant such as Dow Corning® #4 Compound or equivalent.
- (4) A very thin coat of O-ring lubricant should also be applied to the inner walls of the cylinder.

D. REASSEMBLY

- (1) Replace the piston in the cylinder.
- (2) Make sure the tapped holes in the piston are aligned with corresponding holes in the cylinder.
- (3) Replace the spacers and springs.
- (4) Replace the pressure plate and screws making sure screws are tightened to uniform torque based on bolt size and use proper Loctite® (or equivalent) compound to ensure a permanent mount.
- (5) Inspect the inside diameter of the bearing in the air cylinder. If Loctite® residue is present, gently scrape and ensure that the surface is clean.
- (6) Apply a thin coat of Loctite® #609 retainer compound to the inside diameter of the air cylinder bearing, then slide the air cylinder/bearing sub-assembly over the drive hub. Applying excessive Loctite® will make future disassembly more difficult.
- (7) Make sure that all components are well seated and replace the outer retainer ring.
- (8) Reassemble drive disc, friction disc, springs and race section according to reference drawing using new friction discs, springs and steel drive discs as necessary.
- (9) Apply air to the brake.
- (10) Replace retainer ring on drive hub and bolt on top plate.
- (11) See “Brake Installation” portion of these instructions for the proper procedure for reinstalling the brake.

MACH III PRODUCT WARRANTY

Mach III Clutch, Inc. warrants its products to be free from defects in materials and workmanship for a period of one year from the date of shipment from our factory or from the location of one of our authorized distributors provided the product is properly installed, maintained and has been operated under normal conditions. This warranty shall not apply to products that have been subject to misuse, negligence or accident, or damaged by circumstances beyond the control of Mach III Clutch, Inc., or which has been used in a manner contrary to Mach III Clutch, Inc.'s instructions or recommendations. Products that have been altered after shipment or repaired without following proper repair procedures, as deemed by Mach III Clutch, Inc., are also expressly excluded from this warranty.

Warranty claims shall be made in writing and the product(s) shall, if requested by Mach III Clutch, Inc., be returned with transportation charges prepaid for evaluation. Upon our determination that a defect exists, Mach III Clutch, Inc., at its sole discretion, will either repair or replace the defective component(s) or product(s).

THIS WARRANTY IS MADE EXPRESSLY IN LIEU OF ANY OTHER WARRANTIES, EXPRESS OR IMPLIED, INCLUDING ANY IMPLIED WARRANTY OF MERCHANTABILITY OR FITNESS FOR A PARTICULAR PURPOSE. THE BUYER'S SOLE AND EXCLUSIVE REMEDY SHALL BE FOR THE REPAIR OR REPLACEMENT OF DEFECTIVE PRODUCTS AS PROVIDED HEREIN AND UNDER NO CIRCUMSTANCES WILL MACH III CLUTCH, INC.'S LIABILITY EXCEED THE PRICE OF THE DEFECTIVE UNITS. THE BUYER AGREES THAT NO OTHER REMEDY (INCLUDING, BUT NOT LIMITED TO, INCIDENTAL OR CONSEQUENTIAL DAMAGES FOR LOST PROFITS, LOST SALES, INJURY TO PERSON OR PROPERTY OR ANY OTHER INCIDENTAL OR CONSEQUENTIAL LOSS) SHALL BE AVAILABLE TO HIM OR HER.

Mach III Clutch, Inc. neither assumes nor authorizes any person to assume for it any other liability in connection with the sale of its products.



Mach III Clutch, Inc.
101 Cummings Drive
Walton, KY 41094 USA
www.machiii.com
859-291-0849