



5107

Compact Clutch for Rifle Drilled Shaft

Sprocket Size

Chain Size	35
Number of Teeth	60

Engagement/Disengagement

Air/Spring

Facing Type

High Coefficient

Torque @ 80 PSI – Dynamic

1,825 Pound Inches

Minimum Engagement Pressure

1 PSI

Maximum Operating Pressure

80 PSI

Maximum RPM

150

Bore with Standard Keyway

1.500

Air Volume New

1.12 Cubic Inches

Air Volume Worn

4.58 Cubic Inches

Finish

Aluminum

Open or Enclosed Construction

Open

Shipping Weight

6 Pounds

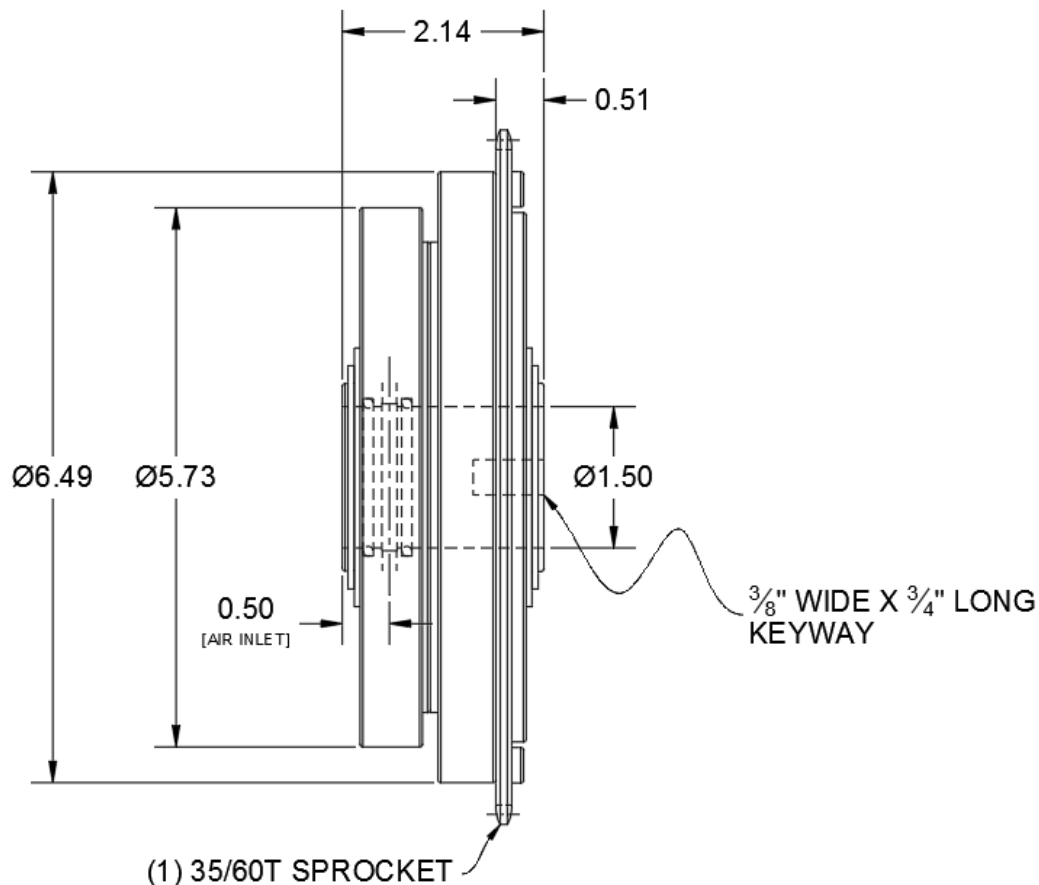

TORQUE vs. AIR PRESSURE

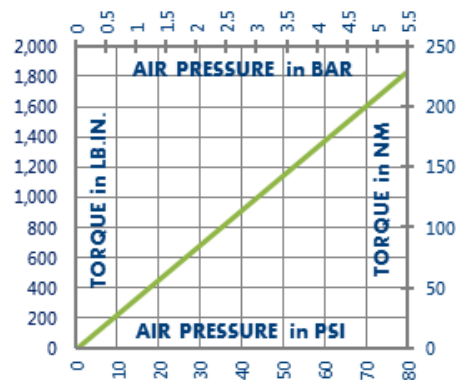

NEW vs. BURNISHED TORQUE

New clutch or brake torque is approximately 40% less than rated design torque until the friction and drive discs are worn in (lapped, burnished). The length of time for wear-in to occur varies by application.

When calculating required torque always use a service factor of 1.5 to 2. It is not recommended to select a product for use at its maximum rated torque for continuous duty.

PRODUCT SELECTION

Torque capacity is only one factor to consider when making a product selection. Insure that you will have right product for the job by contacting our engineering department for application review and selection assistance.



859-291-0849

engineering@machiii.com

www.machiii.com

5107

Parts Diagram

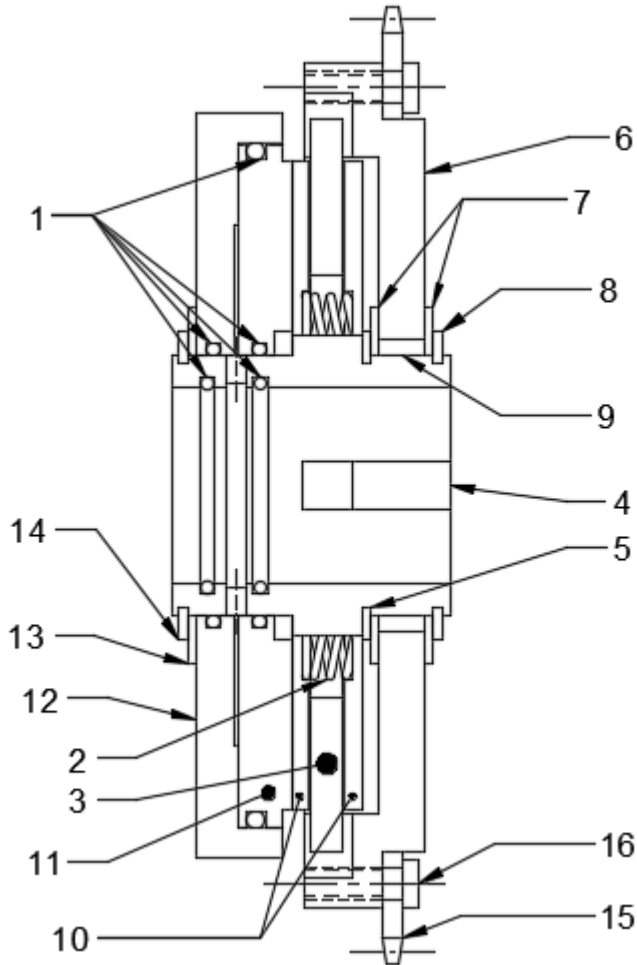

REF#	DESCRIPTION & PARTS INCLUDED	QUANTITY	KIT NUMBER
	REPAIR KIT		5107-RPRK
1	O-Ring	5	
2	Coil Spring	6	
3	Friction Disc	1	
	DRIVE HUB KIT		5107-HUBK
4	Drive Hub	1	
5	Retainer Ring	1	
	SLEEVE KIT		5107-SLVK
6	Sleeve	1	
7	Race	2	
8	Retainer Ring	1	
9	Bushing	1	
	DRIVE DISC KIT		5107-DRDK
10	Drive Disc	2	
11	PISTON	1	5107-P004
	CYLINDER KIT		5107-CYLK
12	Cylinder	1	
13	Race	1	
14	Retainer Ring	1	
	SPROCKET KIT		5107-SPRK
15	Sprocket	1	
16	Screw	6	

PARTS KITS

The *Repair Kit* contains common wear items for this product. Users are encouraged to stock one or more repair kits considering the number of units installed and the potential downtime if machinery on which the unit is installed is critical equipment. To obtain current pricing and lead time for parts kits, contact customer service.

orders@machiii.com

ADDITIONAL PRODUCT INFORMATION

Click on the links below or copy and paste into your web browser.

To view the Installation & Maintenance Manual for this product:

http://www.machiii.com/PDF/Product-Manuals/CLUTCH_THRUSHAFT_BRNZBUSH_AIR_RD_MANUAL.pdf

For information about the application and use of this and other Mach III products:

<http://machiii.com/Application/Default.asp>



859-291-0849

engineering@machiii.com

www.machiii.com