

Z5A1R-STH

Combination Air Engaged Friction Clutch, Air Engaged Friction Brake, Stop & Start the Shaft



Minimum Sprocket Sizes

Chain Size	50	60	80	100
Minimum Teeth	26	23	18	15

Clutch Engagement/Brake Engagement

Air/Air

Facing Type (Clutch & Brake)

High Coefficient

Clutch Torque @ 80 PSI (max) – Dynamic

1,249 Pound Inches

Brake Torque @ 80 PSI (max) – Dynamic

1,249 Pound Inches

Maximum RPM

1,750

Bore Range with Standard Keyway

0.875 (22) to 1.438 (38) Inches (mm)

Air Volume New (Clutch & Brake)

0.55 Cubic Inches

Air Volume Worn (Clutch & Brake)

3.45 Cubic Inches

Finish

Aluminum

Open or Enclosed Construction

Open

Shipping Weight

15 Pounds

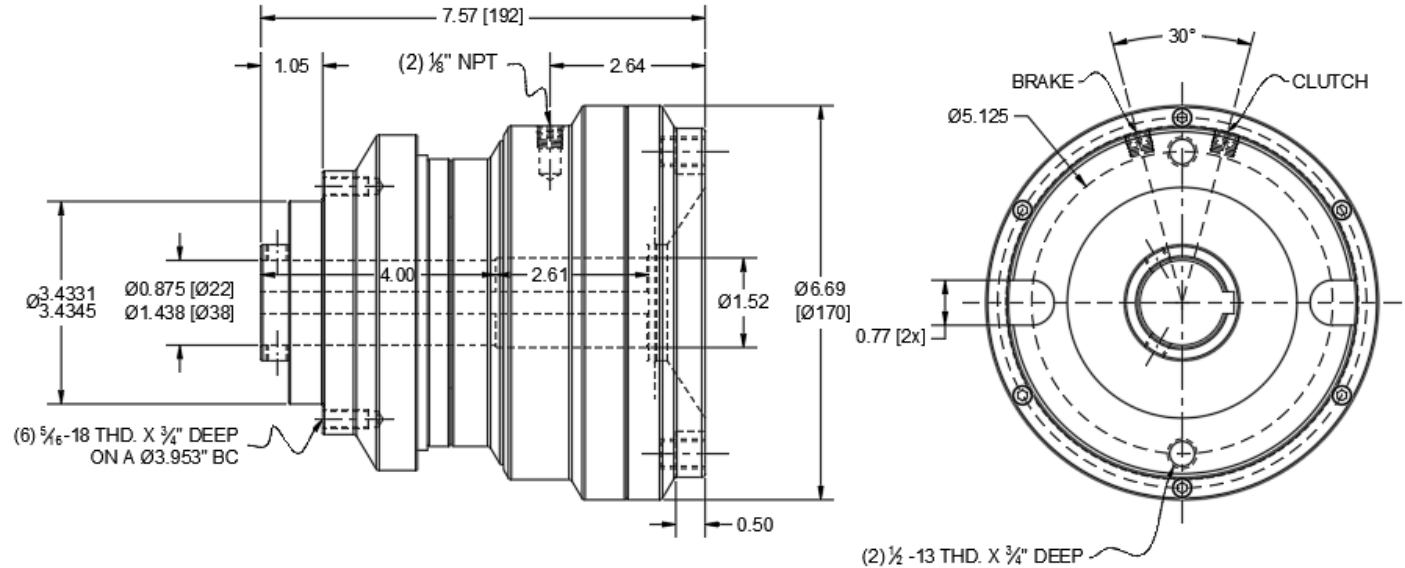

TORQUE vs. AIR PRESSURE

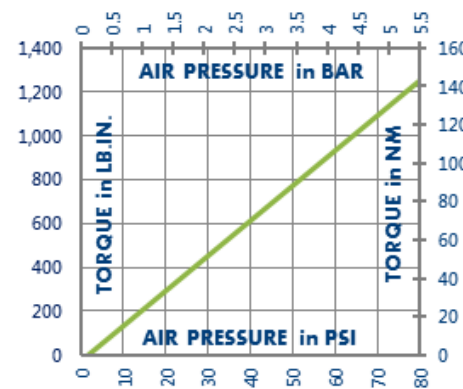

NEW vs. BURNISHED TORQUE

The torque output of a new friction brake or clutch can be up to 40% less than the published torque rating. To achieve full design torque, a unit must be cycled under load to burnish the friction surfaces. The exact number of cycles varies by application.

When calculating required torque always use a safety factor of 1.5 to 2. It is not recommended to select a product for use at its maximum rated torque for continuous duty.

PRODUCT SELECTION

Torque capacity is only one factor to consider when making a product selection. Ensure that you will have the right product for the job by contacting our engineering department for application review and selection assistance.



101 Cummings Drive
Walton, KY 41094 USA

859-291-0849

machiii.com

engineering@machiii.com

Z5A1R-STH

Parts Diagram

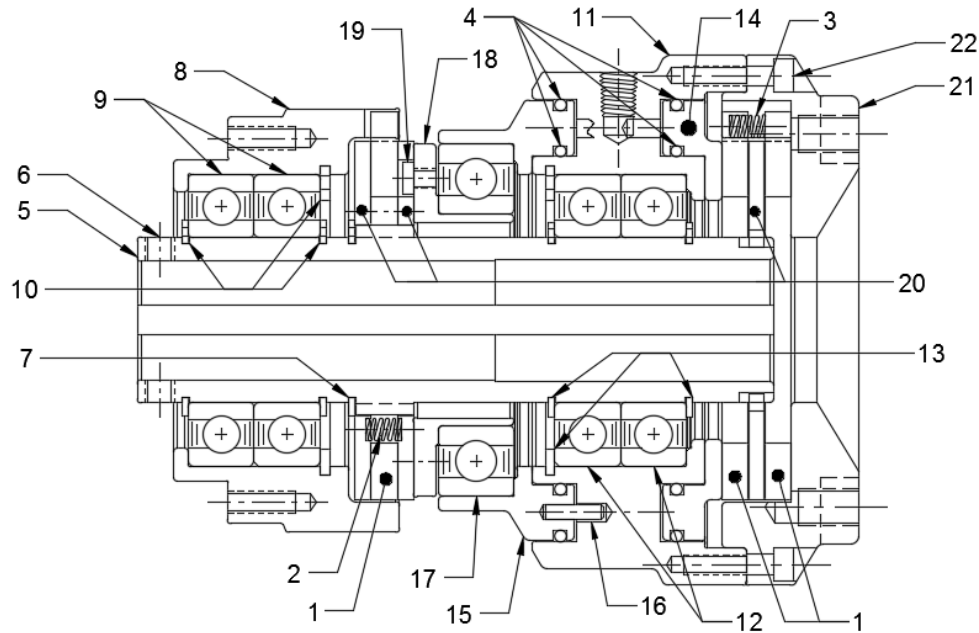

REF#	DESCRIPTION & PARTS INCLUDED	QUANTITY	KIT NUMBER
	REPAIR KIT		Z5A1R-STH-RPRK
1	Friction Disc	3	
2	Coil Spring - Clutch	3	
3	Coil Spring - Brake	3	
4	O-Ring	4	
	DRIVE HUB KIT		Z5A1R-STH-HUBK
5	Drive Hub	1	<i>Specify Bore Size When Ordering</i>
6	Set Screw	2	
7	Retainer Ring	1	
	SLEEVE KIT		Z5A1R-STH-SLVK
8	Sleeve	1	
9	Bearing	2	
10	Retainer Ring	3	
	CYLINDER KIT		Z5A1R-STH-CYLK
11	Cylinder	1	
12	Bearing	2	
13	Retainer Ring	3	
14	PISTON - BRAKE	1	Z5A1R-STH-P0B4
	PISTON KIT - CLUTCH		Z5A1R-STH-PSTK
15	Piston	1	
16	Pin	2	
17	Bearing	1	
18	Cone	1	
19	Screw	1	
	DRIVE DISC KIT		Z5A1R-STH-DRDK
20	Drive Disc	3	
	ADAPTER KIT		Z5A1R-STH-ADPK
21	Brake Adapter	1	
22	Screw	6	

PARTS KITS

The *Repair Kit* contains common wear items for this product. Users are encouraged to stock one or more repair kits considering the number of units installed and the potential downtime if machinery on which the unit is installed is critical equipment. To obtain current pricing and lead time for parts kits, contact customer service.

orders@machiii.com

ADDITIONAL PRODUCT INFORMATION

For illustrated guides showing how Mach III products work, selection guidelines, product manuals, and installation and use recommendations:

<https://machiii.com/resources/how-our-products-work>

For information about how to order, return policy and warranty information:

<https://machiii.com/resources/how-to-order>



859-291-0849

machiii.com

engineering@machiii.com