

Z4A1R-STH

Parts Diagram

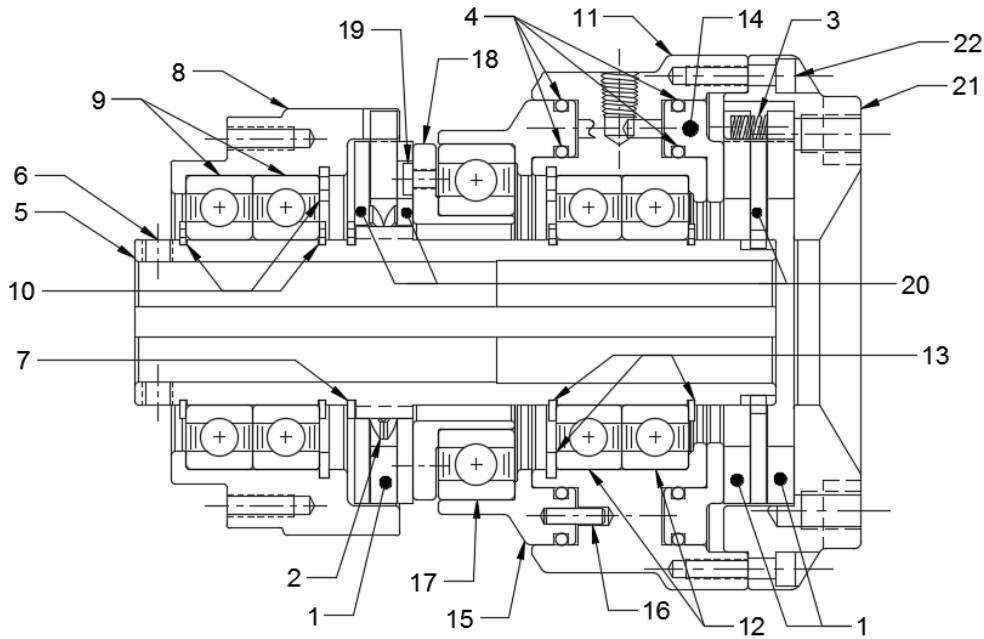

REF#	DESCRIPTION & PARTS INCLUDED	QUANTITY	KIT NUMBER
	REPAIR KIT		Z4A1R-STH-RPRK
1	Friction Disc	3	
2	Wave Spring - Clutch	1	
3	Coil Spring - Brake	3	
4	O-Ring	4	
	DRIVE HUB KIT		Z4A1R-STH-HUBK
5	Drive Hub	1	<i>Specify Bore Size When Ordering</i>
6	Set Screw	2	
7	Retainer Ring	1	
	SLEEVE KIT		Z4A1R-STH-SLVK
8	Sleeve	1	
9	Bearing	2	
10	Retainer Ring	3	
	CYLINDER KIT		Z4A1R-STH-CYLK
11	Cylinder	1	
12	Bearing	2	
13	Retainer Ring	3	
	PISTON - BRAKE		Z4A1R-STH-P0B4
14	Piston	1	
	PISTON KIT - CLUTCH		Z4A1R-STH-PSTK
15	Piston	1	
16	Pin	2	
17	Bearing	1	
18	Cone	1	
19	Screw	1	
	DRIVE DISC KIT		Z4A1R-STH-DRDK
20	Drive Disc	3	
	ADAPTER KIT		Z4A1R-STH-ADPK
21	Brake Adapter	1	
22	Screw	6	

PARTS KITS

The *Repair Kit* contains common wear items for this product. Users are encouraged to stock one or more repair kits considering the number of units installed and the potential downtime if machinery on which the unit is installed is critical equipment. To obtain current pricing and lead time for parts kits, contact customer service.

orders@machiii.com

ADDITIONAL PRODUCT INFORMATION

For illustrated guides showing how Mach III products work, selection guidelines, product manuals, and installation and use recommendations:

<https://machiii.com/resources/how-our-products-work>

For information about how to order, return policy and warranty information:

<https://machiii.com/resources/how-to-order>



859-291-0849

machiii.com

engineering@machiii.com