

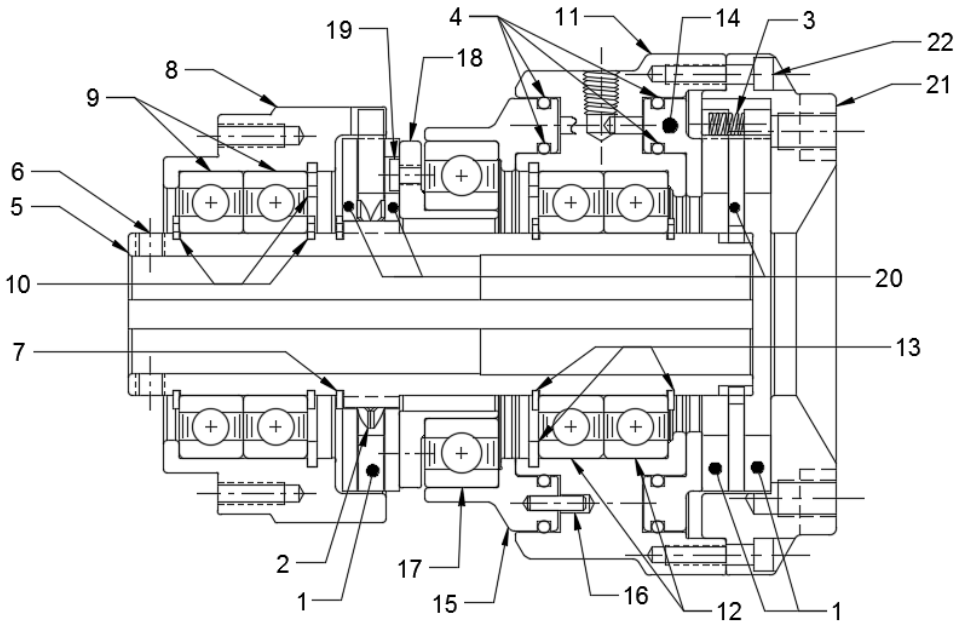

# Z3A1R-STH

## Parts Diagram



REF#	DESCRIPTION & PARTS INCLUDED	QUANTITY	KIT NUMBER
	<b>REPAIR KIT</b>		<b>Z3A1R-STH-RPRK</b>
1	Friction Disc	3	
2	Wave Spring - Clutch	1	
3	Coil Spring - Brake	3	
4	O-Ring	4	
	<b>DRIVE HUB KIT</b>		<b>Z3A1R-STH-HUBK</b>
5	Drive Hub	1	<i>Specify Bore Size When Ordering</i>
6	Set Screw	2	
7	Retainer Ring	1	
	<b>SLEEVE KIT</b>		<b>Z3A1R-STH-SLVK</b>
8	Sleeve	1	
9	Bearing	2	
10	Retainer Ring	3	
	<b>CYLINDER KIT</b>		<b>Z3A1R-STH-CYLK</b>
11	Cylinder	1	
12	Bearing	2	
13	Retainer Ring	3	
	<b>PISTON - BRAKE</b>		<b>Z3A1R-STH-P0B4</b>
14	Piston - Brake	1	
	<b>PISTON KIT - CLUTCH</b>		<b>Z3A1R-STH-PSTK</b>
15	Piston	1	
16	Pin	2	
17	Bearing	1	
18	Cone	1	
19	Screw	1	
	<b>DRIVE DISC KIT</b>		<b>Z3A1R-STH-DRDK</b>
20	Drive Disc	3	
	<b>ADAPTER KIT</b>		<b>Z3A1R-STH-ADPK</b>
21	Brake Adapter	1	
22	Screw	6	

### PARTS KITS

The *Repair Kit* contains common wear items for this product. Users are encouraged to stock one or more repair kits considering the number of units installed and the potential downtime if machinery on which the unit is installed is critical equipment. To obtain current pricing and lead time for parts kits, contact customer service.

[orders@machiii.com](mailto:orders@machiii.com)

### ADDITIONAL PRODUCT INFORMATION

For illustrated guides showing how Mach III products work, selection guidelines, product manuals, and installation and use recommendations:

<https://machiii.com/resources/how-our-products-work>

For information about how to order, return policy and warranty information:

<https://machiii.com/resources/how-to-order>



859-291-0849

[machiii.com](http://machiii.com)

[engineering@machiii.com](mailto:engineering@machiii.com)