

X6G2G-STH

Combination Air Engaged Friction Clutch, Spring Engaged Friction Brake, Stop & Start the Shaft – Double-Single Sprocket



Minimum Sprocket Size

Chain Size	60
Minimum Teeth	27

Clutch Engagement/Brake Engagement

Air/Spring

Facing Type

High Coefficient

Clutch Torque @ 80 PSI (max) – Dynamic

2,706 Pound Inches

Brake Torque @ Spring Pressure (fixed)

256 Pound Inches

Brake Release Pressure

20 - 25 PSI

Maximum RPM

1,750

Bore Range with Standard Keyway

1.125 (29) to 2.000 (52) Inches (mm)

Air Volume New

1.82 Cubic Inches

Air Volume Worn

6.13 Cubic Inches

Finish

Aluminum

Open or Enclosed Construction

Open

Shipping Weight

46 Pounds

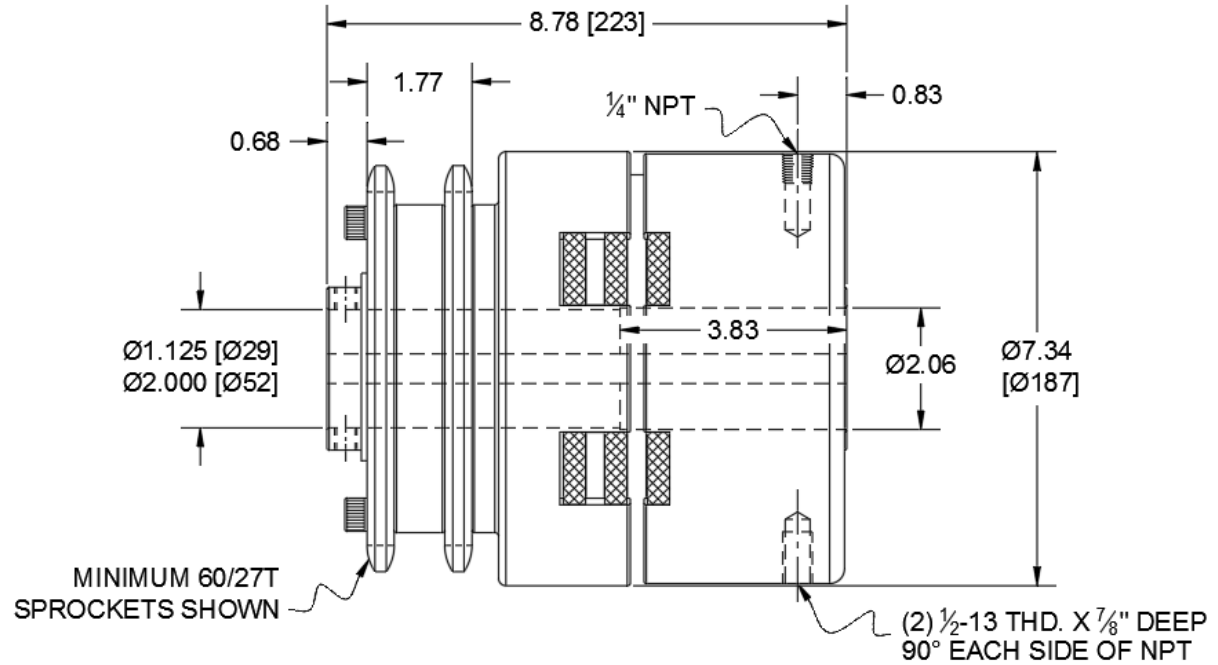

TORQUE vs. AIR PRESSURE

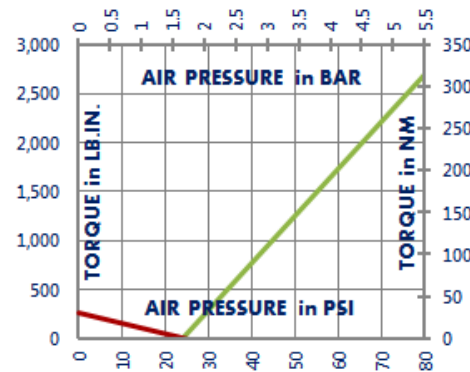

NEW vs. BURNISHED TORQUE

The torque output of a new friction brake or clutch can be up to 40% less than the published torque rating. To achieve full design torque, a unit must be cycled under load to burnish the friction surfaces. The exact number of cycles varies by application.

When calculating required torque always use a safety factor of 1.5 to 2. It is not recommended to select a product for use at its maximum rated torque for continuous duty.

PRODUCT SELECTION

Torque capacity is only one factor to consider when making a product selection. Ensure that you will have the right product for the job by contacting our engineering department for application review and selection assistance.



1580 Lake Street
Elmira, NY 14901 USA
859-291-0849
machiii.com

engineering@machiii.com

X6G2G-STH

Parts Diagram

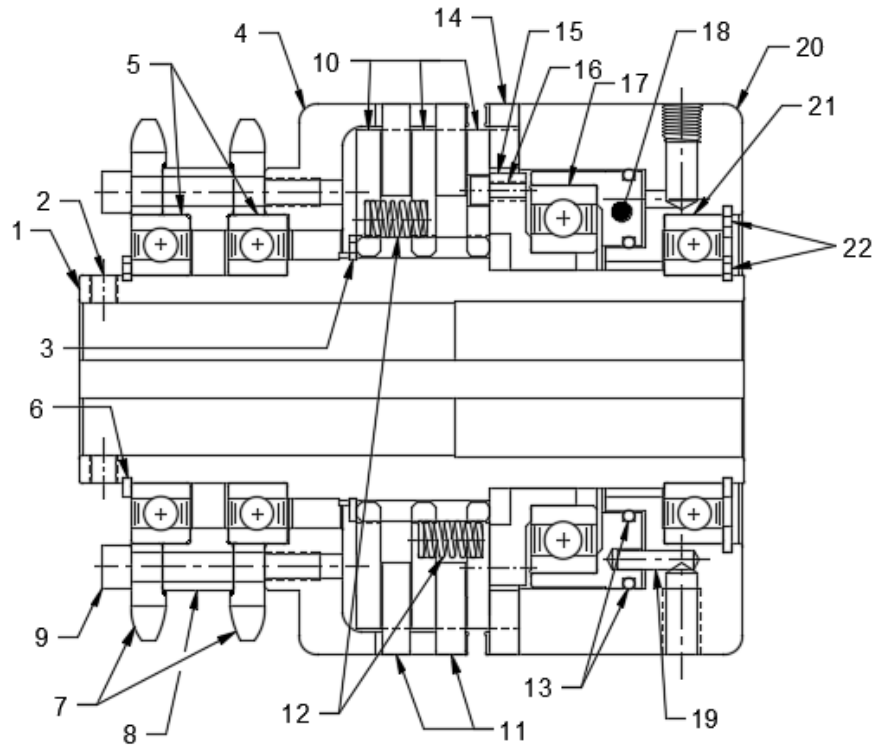

REF#	DESCRIPTION & PARTS INCLUDED	QUANTITY	KIT NUMBER
DRIVE HUB KIT			X6G2G-STH-HUBK
1	Drive Hub	1	<i>Specify Bore Size When Ordering</i>
2	Set Screw	2	
3	Retainer Ring	1	
SLEEVE KIT			X6G2G-STH-SLVK
4	Sleeve	1	
5	Bearing	2	
6	Retainer Ring	1	
7	Sprocket	2	<i>Specify Sprocket Size When Ordering</i>
8	Spacer	1	
9	Screw	6	
DRIVE DISC KIT			W6A2G-STH-DRDK
10	Drive Disc	3	
REPAIR KIT			X6G2G-STH-RPRK
11	Friction Disc	2	
12	Spring	14	
13	O-Ring	2	
14	Brake Friction Disc	1	
PISTON KIT			X6A2G-STH-PSTK
15	Cone	1	
16	Screw	1	
17	Bearing	1	
18	Piston	1	
CYLINDER KIT			X6A2G-STH-CYLK
19	Pins	6	
20	Cylinder	1	
21	Bearing	1	
22	Retainer Ring	2	

PARTS KITS

The *Repair Kit* contains common wear items for this product. Users are encouraged to stock one or more repair kits considering the number of units installed and the potential downtime if machinery on which the unit is installed is critical equipment. To obtain current pricing and lead time for parts kits, contact customer service.

orders@machiii.com

ADDITIONAL PRODUCT INFORMATION

For illustrated guides showing how Mach III products work, selection guidelines, product manuals, and installation and use recommendations:

<https://machiii.com/resources/how-our-products-work>

For information about how to order, return policy and warranty information:

<https://machiii.com/resources/how-to-order>



859-291-0849

machiii.com

engineering@machiii.com