

# T6A1G-STL

Mechanical Friction Torque Limiter  
Through Shaft Bored, Pilot Mount



Designed for brief overloads.  
Does not automatically disconnect.

## Minimum Sprocket Sizes

Chain Size	50	60	80	100
Minimum Teeth	34	29	23	19

## Engagement/Disengagement

Spring/None

## Facing Type

Low Coefficient

## Minimum Torque Setting

310 Pound Inches

## Maximum Torque Setting (Spring Compression ≈ 17%)

3,070 Pound Inches

## Maximum RPM

1,750

## Bore Range with Standard Keyway

1.125 (29) to 2.000 (52) Inches (mm)

## Finish

Aluminum

## Open or Enclosed Construction

Open

## Shipping Weight

40 Pounds

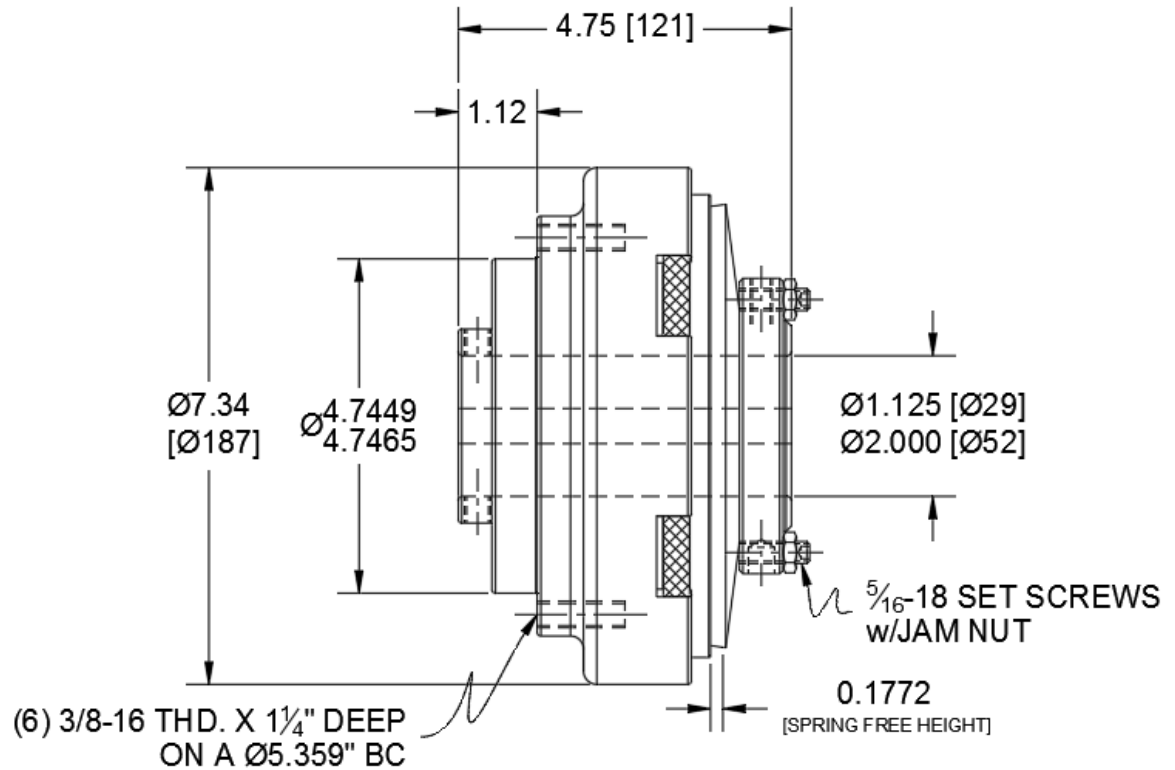

## TORQUE vs. SPRING PRESSURE

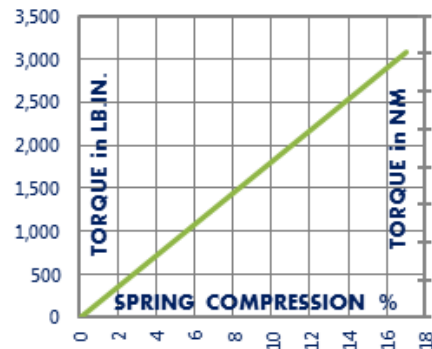

## NEW vs. BURNISHED TORQUE

The torque output setting of a friction torque limiter is set at the factory or in the field when new. (All torque settings are +/- 10%.) Repeated overload will burnish the friction surfaces and may increase the slip torque setting. The torque setting should be tested after prolonged or frequent overload and re-set if needed.

## PRODUCT SELECTION

Torque capacity is only one factor to consider when making a product selection. Ensure that you will have the right product for the job by contacting our engineering department for application review and selection assistance.



101 Cummings Drive  
Walton, KY 41094 USA  
859-291-0849  
machiii.com

engineering@machiii.com

# T6A1G-STL

## Parts Diagram

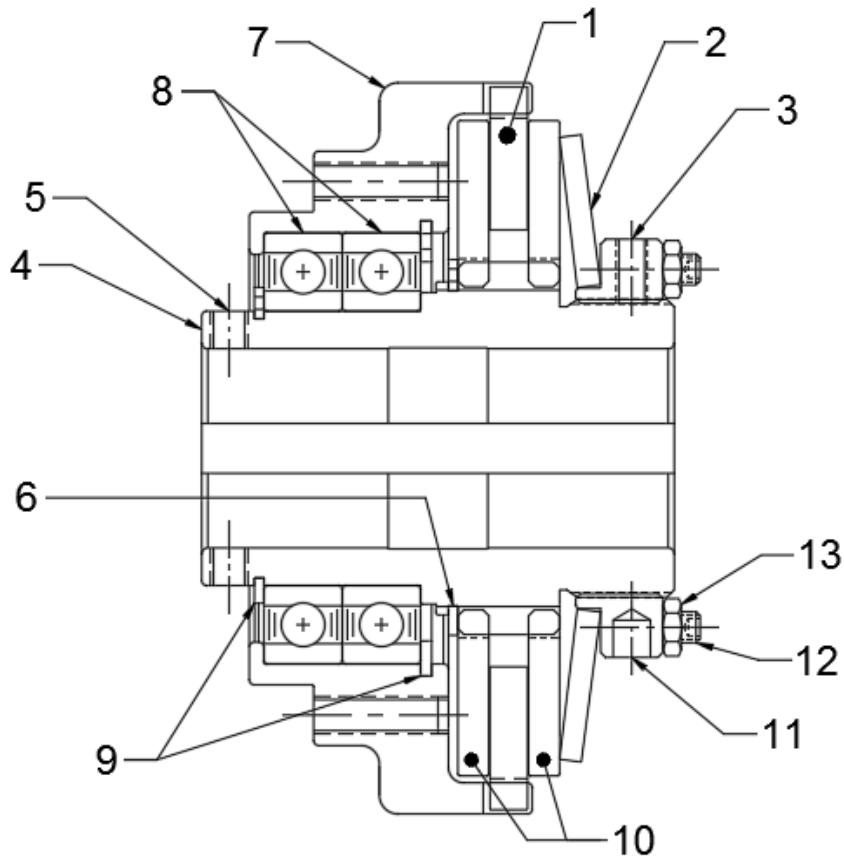

REF#	DESCRIPTION & PARTS INCLUDED	QUANTITY	KIT NUMBER
	<b>REPAIR KIT</b>		<b>T6A1G-STL-RPRK</b>
1	Friction Disc	1	
2	Disc Spring	1	
3	Nylon Point Set Screw	1	
	<b>DRIVE HUB KIT</b>		<b>T6A1G-STL-HUBK</b>
4	Drive Hub	1	<i>Specify Bore Size When Ordering</i>
5	Set Screw	2	
6	Retainer Ring	1	
	<b>SLEEVE KIT</b>		<b>T6A1G-STL-SLVK</b>
7	Sleeve	1	
8	Bearing	2	
9	Retainer Ring	2	
	<b>DRIVE DISC KIT</b>		<b>T6A1G-STL-DRDK</b>
10	Drive Disc	2	
	<b>FACING KIT</b>		<b>T6A1G-STL-FCGK</b>
1	Friction Disc	1	
3	Nylon Point Set Screw	1	
	<b>NUT KIT</b>		<b>T6A1G-STL-NUTK</b>
11	Nut	1	
12	Oval Point Set Screw	6	
13	Jam Nut	6	
3	Nylon Point Set Screw	1	

### PARTS KITS

The *Repair Kit* contains common wear items for this product. Users are encouraged to stock one or more repair kits considering the number of units installed and the potential downtime if machinery on which the unit is installed is critical equipment. To obtain current pricing and lead time for parts kits, contact customer service.

[orders@machiii.com](mailto:orders@machiii.com)

### ADDITIONAL PRODUCT INFORMATION

For illustrated guides showing how Mach III products work, selection guidelines, product manuals, and installation and use recommendations:

<https://machiii.com/resources/how-our-products-work>

For information about how to order, return policy and warranty information:

<https://machiii.com/resources/how-to-order>



859-291-0849

[machiii.com](http://machiii.com)

[engineering@machiii.com](mailto:engineering@machiii.com)