

T3C2H-56L

Mechanical Friction Torque Limiter
NEMA 56C Frame Mount



Designed for brief overloads.
Does not automatically disconnect.

NOT suitable for pulley output

Engagement/Disengagement

Spring/None

Facing Type

Low Coefficient

Minimum Torque Setting

80 Pound Inches

Maximum Torque Setting (Spring Compression ≈ 31%)

792 Pound Inches

Maximum RPM

1,750

Input Bore/Output Shaft

0.625 Inches

Finish

Aluminum

Open or Enclosed Construction

Enclosed

Shipping Weight

12 Pounds

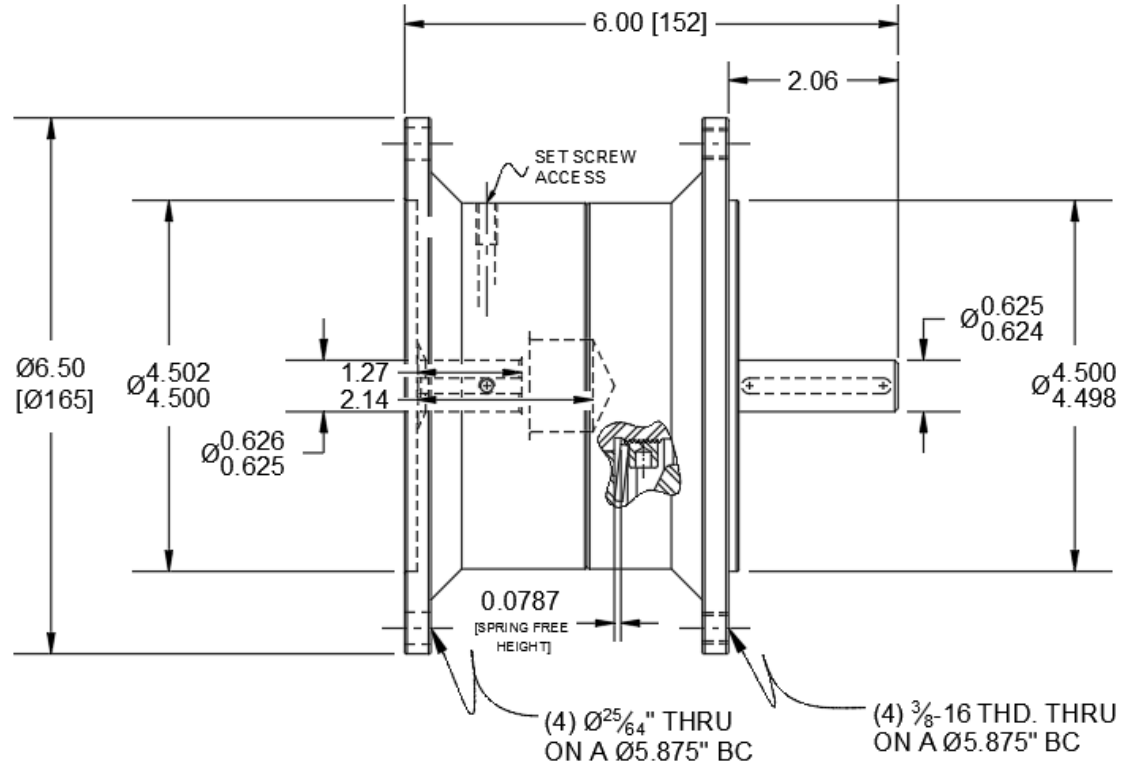

TORQUE vs. SPRING PRESSURE

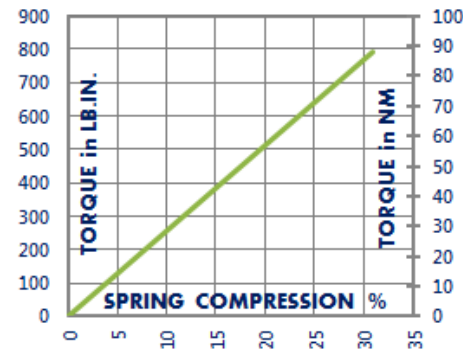

NEW vs. BURNISHED TORQUE

The torque output setting of a friction torque limiter is set at the factory or in the field when new. (All torque settings are +/- 10%.) Repeated overload will burnish the friction surfaces and may increase the slip torque setting. The torque setting should be tested after prolonged or frequent overload and re-set if needed.

PRODUCT SELECTION

Torque capacity is only one factor to consider when making a product selection. Ensure that you will have the right product for the job by contacting our engineering department for application review and selection assistance.



101 Cummings Drive
Walton, KY 41094 USA
859-291-0849
machiii.com

engineering@machiii.com

T3C2H-56L

Parts Diagram

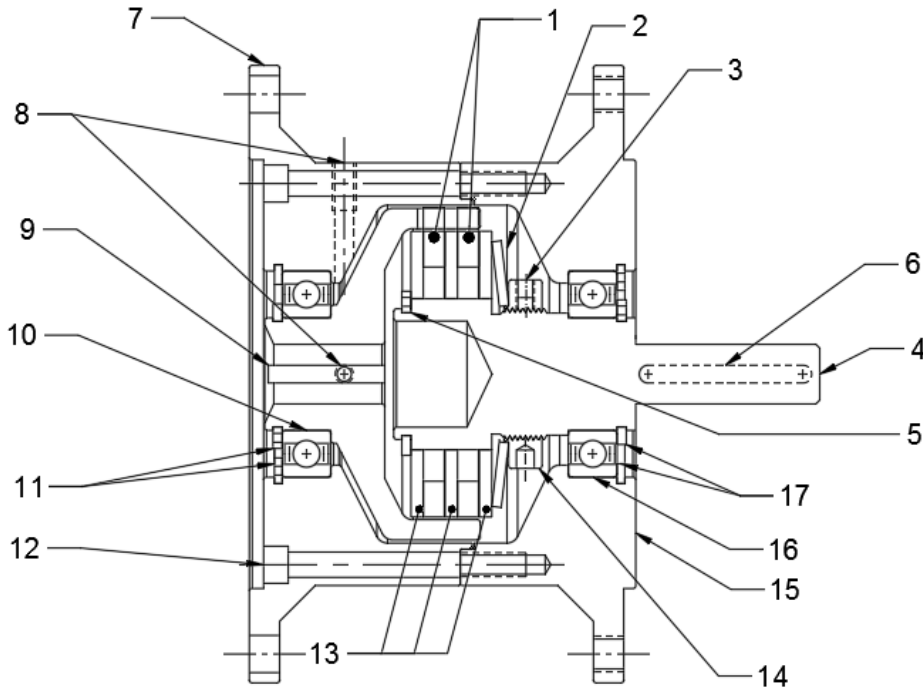

REF#	DESCRIPTION & PARTS INCLUDED	QUANTITY	KIT NUMBER
	REPAIR KIT		T3C2H-56L-RPRK
1	Friction Disc	2	
2	Disc Spring	1	
3	Nylon Point Set Screw	1	
	DRIVE HUB KIT		T3C2H-56L-HUBK
4	Drive Hub	1	
5	Retainer Ring	1	
6	Key Stock	1	
	SLEEVE KIT		C3C2H-STH-SLVK
7	Adapter Female	1	
8	Set Screw	2	
9	Sleeve	1	
10	Bearing	1	
11	Retainer Ring	2	
12	Screw	3	
	DRIVE DISC KIT		C3D2H-STH-DRDK
13	Drive Disc	3	
	FACING KIT		T3C2H-56L-FCGK
1	Friction Disc	2	
3	Nylon Point Set Screw	1	
	NUT KIT		3000-NUTK
14	Nut	1	
3	Nylon Point Set Screw	1	
	ADAPTER KIT		T3C2H-56L-ADPK
15	Adapter Male	1	
16	Bearing	1	
17	Retainer Ring	2	

PARTS KITS

The *Repair Kit* contains common wear items for this product. Users are encouraged to stock one or more repair kits considering the number of units installed and the potential downtime if machinery on which the unit is installed is critical equipment. To obtain current pricing and lead time for parts kits, contact customer service.

orders@machiii.com

ADDITIONAL PRODUCT INFORMATION

For illustrated guides showing how Mach III products work, selection guidelines, product manuals, and installation and use recommendations:

<https://machiii.com/resources/how-our-products-work>

For information about how to order, return policy and warranty information:

<https://machiii.com/resources/how-to-order>



859-291-0849

machiii.com

engineering@machiii.com