

M6R2K-STH

Air Engaged Friction Clutch
Mechanism with Adapter



Important: Both shaft and connected component must be bearing supported.

Engagement/Disengagement

Air/Spring

Facing Type

High Coefficient

Torque @ 80 PSI – Dynamic

5,397 Pound Inches

Minimum Engagement Pressure

4 PSI

Maximum Operating Pressure

80 PSI

Maximum RPM

1,650

Bore Range with Standard Keyway

1.375 (35) to 2.000 (52) Inches (mm)

Air Volume New

1.54 Cubic Inches

Air Volume Worn

9.40 Cubic Inches

Finish

Aluminum

Open or Enclosed Construction

Open

Component Mounting Bolt Circle

5.375 Inches

Shipping Weight

30 Pounds

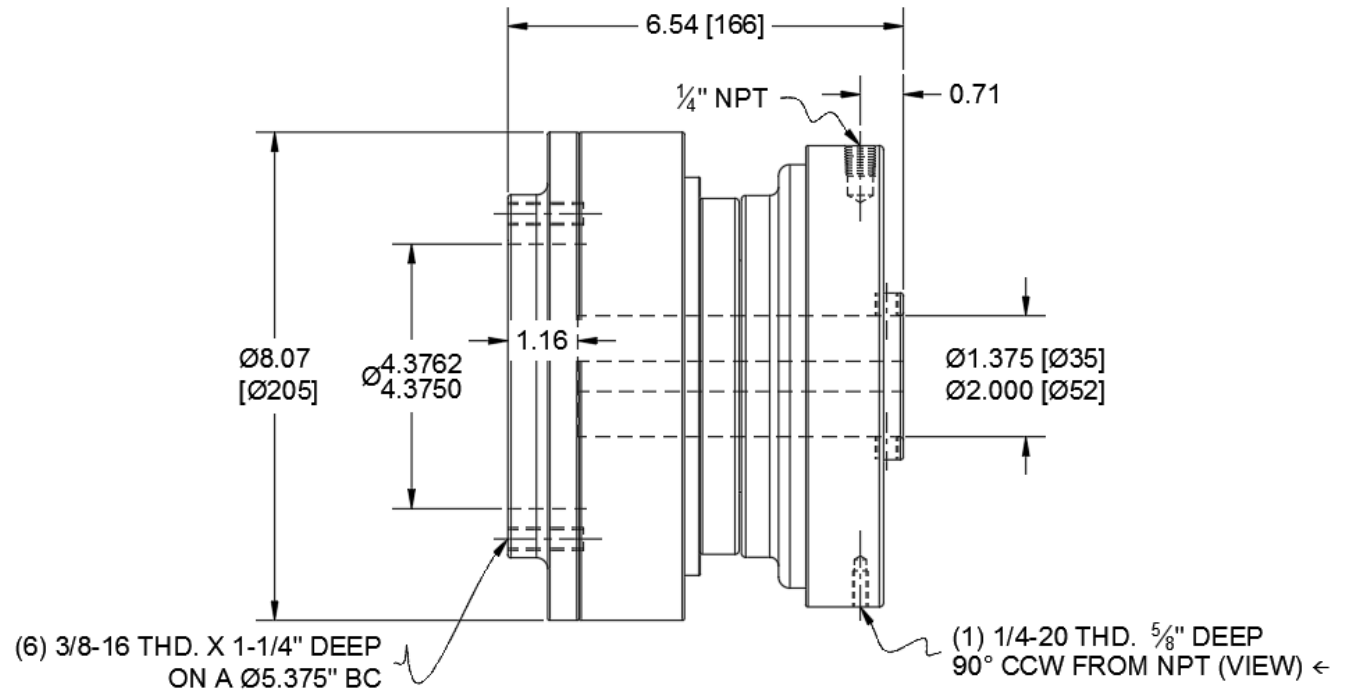

TORQUE vs. AIR PRESSURE

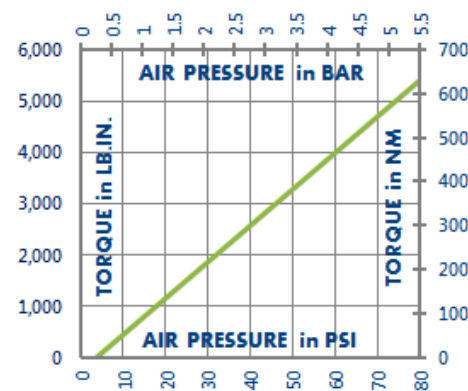

NEW vs. BURNISHED TORQUE

The torque output of a new friction brake or clutch can be up to 40% less than the published torque rating. To achieve full design torque, a unit must be cycled under load to burnish the friction surfaces. The exact number of cycles varies by application.

When calculating required torque always use a safety factor of 1.5 to 2. It is not recommended to select a product for use at its maximum rated torque for continuous duty.

PRODUCT SELECTION

Torque capacity is only one factor to consider when making a product selection. Ensure that you will have the right product for the job by contacting our engineering department for application review and selection assistance.



101 Cummings Drive
Walton, KY 41094 USA

859-291-0849

machiii.com

engineering@machiii.com

M6R2K-STH

Parts Diagram

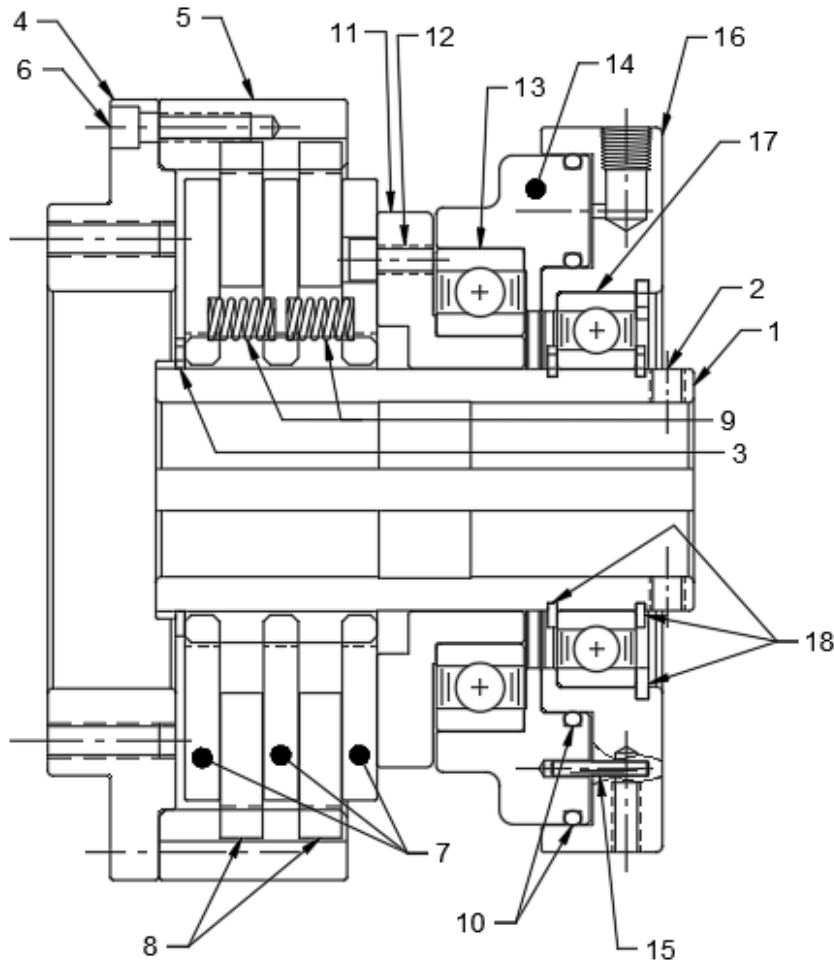

REF#	DESCRIPTION & PARTS INCLUDED	QUANTITY	KIT NUMBER
DRIVE HUB KIT			M6G2G-STH-HUBK
1	Drive Hub	1	<i>Specify Bore Size When Ordering</i>
2	Set Screw	2	
3	Retainer Ring	1	
ADAPTER KIT			M6R2K-STH-ADPK
4	Adapter	1	
5	Ring Gear	1	
6	Screw	7	
DRIVE DISC KIT			C6A2G-STH-DRDK
7	Drive Disc	3	
REPAIR KIT			M6R2K-STH-RPRK
8	Friction Disc	2	
9	Coil Spring	6	
10	O-Ring	2	
PISTON KIT			C6A2G-STH-PSTK
11	Cone	1	
12	Screw	1	
13	Bearing	1	
14	Piston	1	
CYLINDER KIT			C6A2G-STH-CYLK
15	Pin	2	
16	Cylinder	1	
17	Bearing	1	
18	Retainer Ring	3	

PARTS KITS

The *Repair Kit* contains common wear items for this product. Users are encouraged to stock one or more repair kits considering the number of units installed and the potential downtime if machinery on which the unit is installed is critical equipment. To obtain current pricing and lead time for parts kits, contact customer service.

orders@machiii.com

ADDITIONAL PRODUCT INFORMATION

For illustrated guides showing how Mach III products work, selection guidelines, product manuals, and installation and use recommendations:

<https://machiii.com/resources/how-our-products-work>

For information about how to order, return policy and warranty information:

<https://machiii.com/resources/how-to-order>



859-291-0849

machiii.com

engineering@machiii.com