

# E6D3K-STH

Spring Engaged Friction Clutch  
End of Shaft Bored, Pilot Mount



## Minimum Sprocket Sizes

Chain Size	50	60	80	100
Minimum Teeth	34	29	23	19

## Engagement/Disengagement

Spring/Air

## Facing Type

High Coefficient

## Torque @ 0 PSI – Dynamic

4,957 Pound Inches

## Minimum Disengagement Pressure

77 PSI

## Maximum Operating Pressure

90 PSI

## Maximum RPM

1,650

## Bore Range with Standard Keyway

1.375 (35) to 2.000 (52) Inches (mm)

## Air Volume/Cycle

4.22 Cubic Inches

## Finish

Aluminum

## Open or Enclosed Construction

Enclosed

## Shipping Weight

33 Pounds

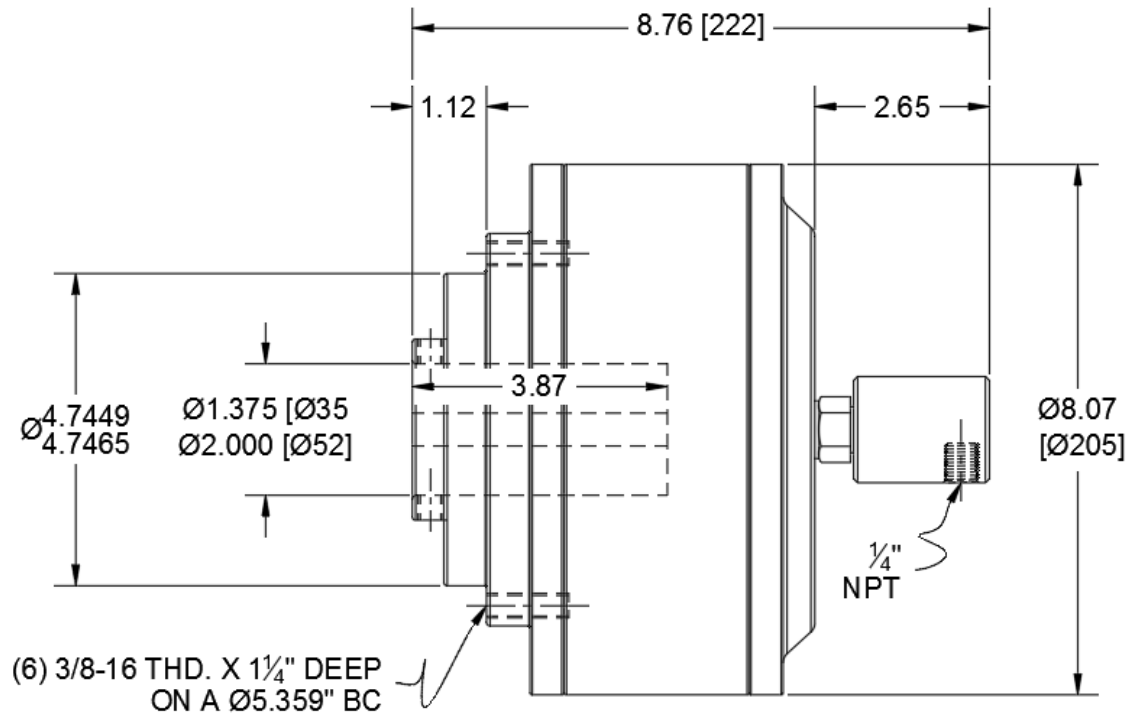

## TORQUE vs. AIR PRESSURE

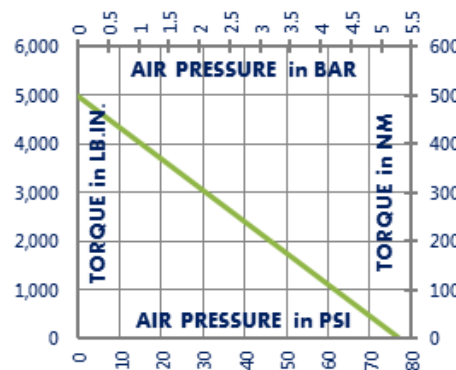

## NEW vs. BURNISHED TORQUE

The torque output of a new friction brake or clutch can be up to 40% less than the published torque rating. To achieve full design torque, a unit must be cycled under load to burnish the friction surfaces. The exact number of cycles varies by application.

When calculating required torque always use a safety factor of 1.5 to 2. It is not recommended to select a product for use at its maximum rated torque for continuous duty.

## PRODUCT SELECTION

Torque capacity is only one factor to consider when making a product selection. Ensure that you will have the right product for the job by contacting our engineering department for application review and selection assistance.



101 Cummings Drive  
Walton, KY 41094 USA

859-291-0849

[machiii.com](http://machiii.com)

[engineering@machiii.com](mailto:engineering@machiii.com)

# E6D3K-STH

## Parts Diagram

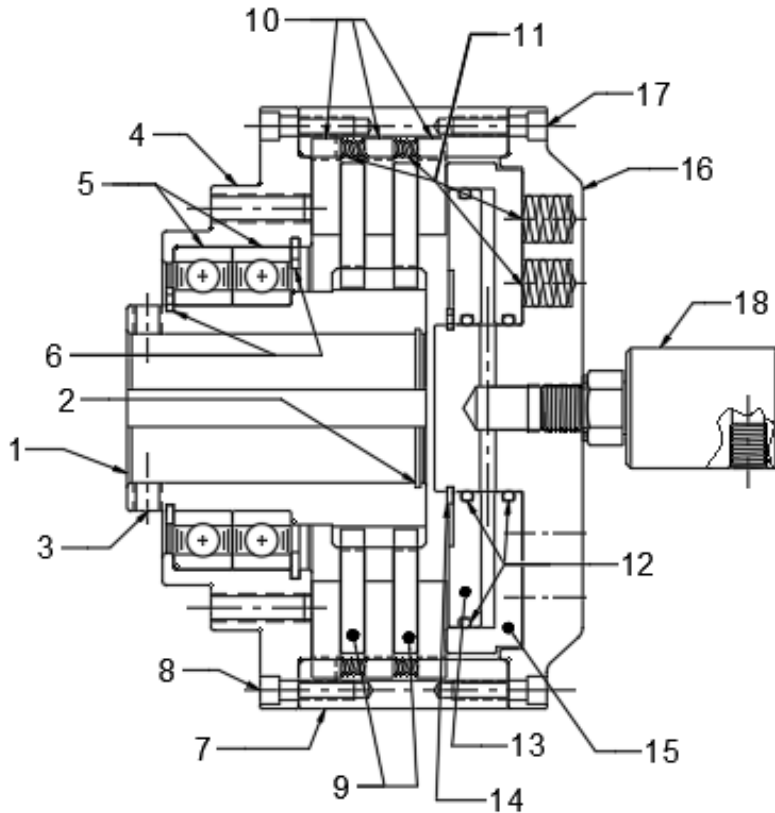

REF#	DESCRIPTION & PARTS INCLUDED	QUANTITY	KIT NUMBER
	<b>DRIVE HUB KIT</b>		<b>C6D3K-STH-HUBK</b>
1	Drive Hub	1	<i>Specify Bore Size When Ordering</i>
2	Retainer Ring	1	
3	Set Screw	2	
	<b>SLEEVE KIT</b>		<b>E6D3K-STH-SLVK</b>
4	Sleeve	1	
5	Bearing	2	
6	Retainer Ring	2	
7	Ring Gear	1	
8	Screw	7	
	<b>DRIVE DISC KIT</b>		<b>E6D3K-STH-DRDK</b>
9	Drive Disc	2	
	<b>REPAIR KIT</b>		<b>E6D3K-STH-RPRK</b>
10	Friction Disc	3	
11	Coil Spring	39	
12	O-Ring	3	
	<b>PISTON KIT</b>		<b>E6D3K-STH-PSTK</b>
13	Piston	1	
14	Retainer Ring	1	
15	Spring Retainer	1	
	<b>CYLINDER KIT</b>		<b>E6D3K-STH-CYLK</b>
16	Cylinder	1	
17	Screw	7	
18	<b>CYLINDER KIT</b>	1	<b>RSEAL-031</b>

### PARTS KITS

The *Repair Kit* contains common wear items for this product. Users are encouraged to stock one or more repair kits considering the number of units installed and the potential downtime if machinery on which the unit is installed is critical equipment. To obtain current pricing and lead time for parts kits, contact customer service.

orders@machiii.com

### ADDITIONAL PRODUCT INFORMATION

For illustrated guides showing how Mach III products work, selection guidelines, product manuals, and installation and use recommendations:

<https://machiii.com/resources/how-our-products-work>

For information about how to order, return policy and warranty information:

<https://machiii.com/resources/how-to-order>



859-291-0849

machiii.com

engineering@machiii.com