

E5A2R-STH

Spring Engaged Friction Clutch
Through Shaft Bored, Pilot Mount



Minimum Sprocket Sizes

Chain Size	40	50	60	80
Minimum Teeth	32	26	23	18

Engagement/Disengagement

Spring/Air

Facing Type

High Coefficient

Torque @ 0 PSI – Dynamic

2,502 Pound Inches

Minimum Disengagement Pressure

75 PSI

Maximum Operating Pressure

90 PSI

Maximum RPM

1,750

Bore Range with Standard Keyway

1.125 (29) to 1.438 (38) Inches (mm)

Air Volume/Cycle

1.73 Cubic Inches

Finish

Aluminum

Open or Enclosed Construction

Open

Shipping Weight

23 Pounds

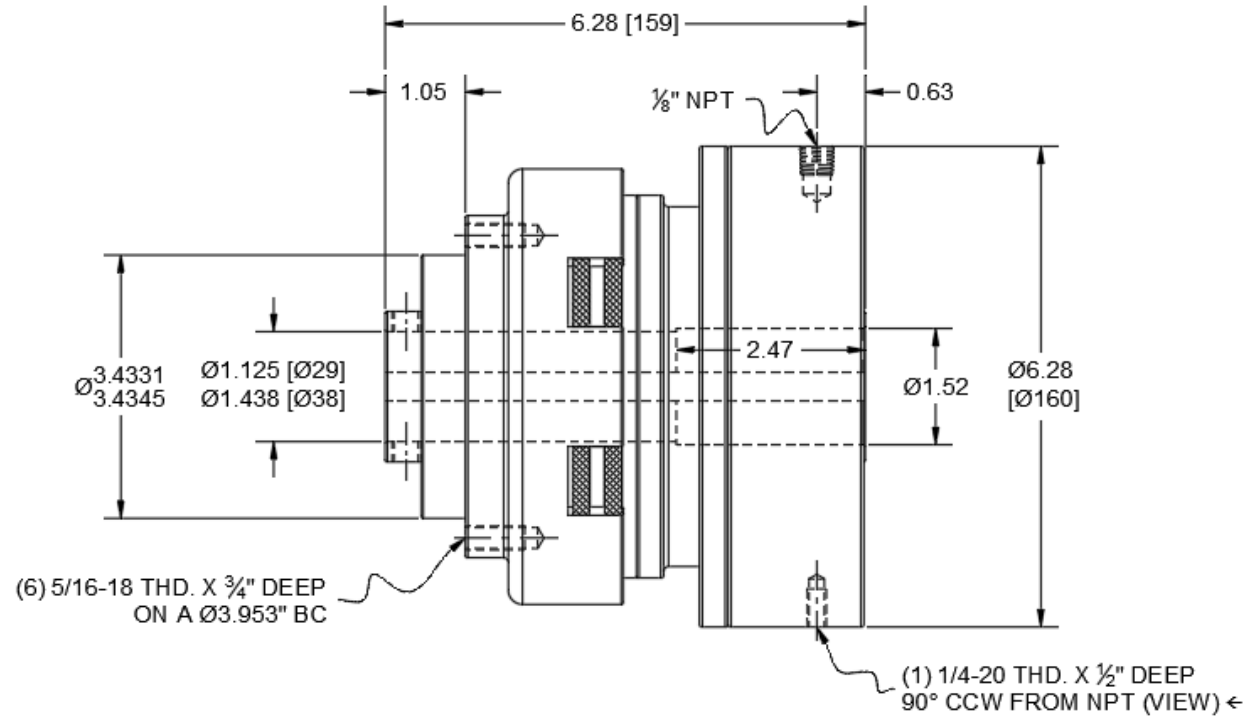

TORQUE vs. AIR PRESSURE

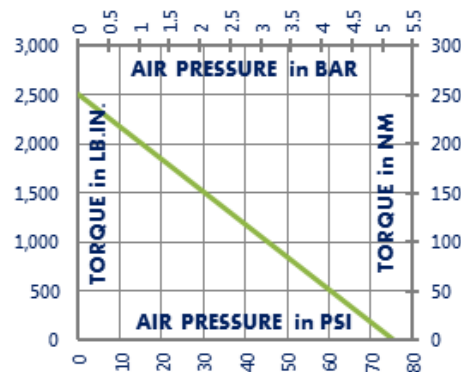

NEW vs. BURNISHED TORQUE

The torque output of a new friction brake or clutch can be up to 40% less than the published torque rating. To achieve full design torque, a unit must be cycled under load to burnish the friction surfaces. The exact number of cycles varies by application.

When calculating required torque always use a safety factor of 1.5 to 2. It is not recommended to select a product for use at its maximum rated torque for continuous duty.

PRODUCT SELECTION

Torque capacity is only one factor to consider when making a product selection. Ensure that you will have the right product for the job by contacting our engineering department for application review and selection assistance.



101 Cummings Drive
Walton, KY 41094 USA

859-291-0849

machiii.com

engineering@machiii.com

E5A2R-STH

Parts Diagram

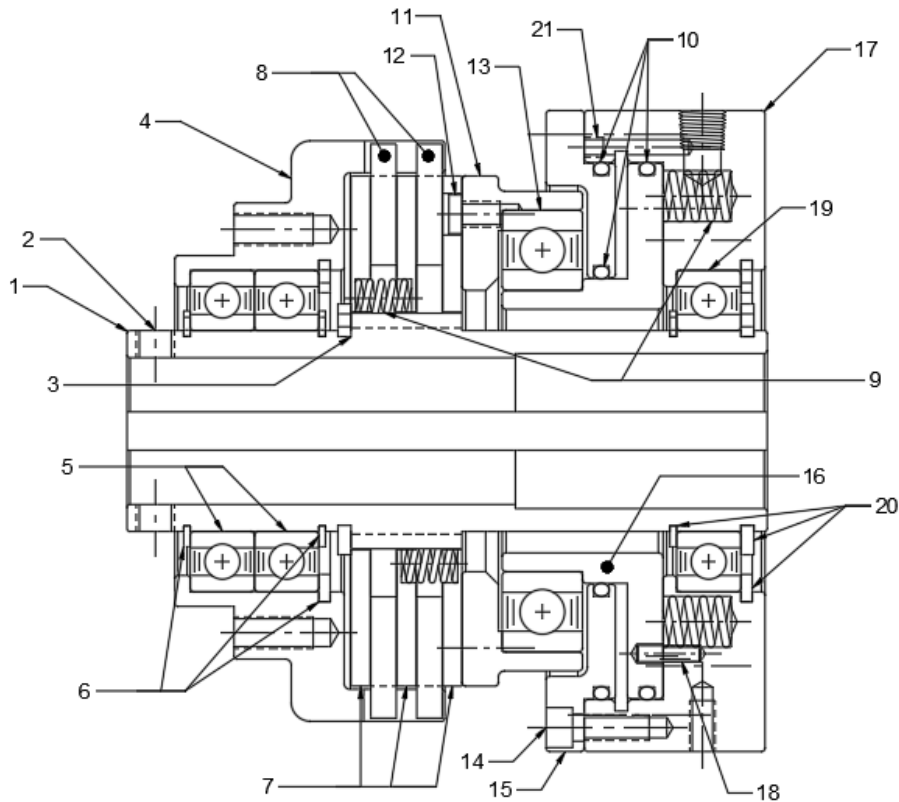

REF#	DESCRIPTION & PARTS INCLUDED	QUANTITY	KIT NUMBER
DRIVE HUB KIT			C5A2R-STH-HUBK
1	Drive Hub	1	<i>Specify Bore Size When Ordering</i>
2	Set Screw	2	
3	Retainer Ring	1	
SLEEVE KIT			C5A2H-STH-SLVK
4	Sleeve	1	
5	Bearing	2	
6	Retainer Ring	3	
DRIVE DISC KIT			C5A2R-STH-DRDK
7	Drive Disc	3	
REPAIR KIT			E5A2R-STH-RPRK
8	Friction Disc	2	
9	Coil Spring	4	
10	O-Ring	3	
PISTON KIT			E5A2R-STH-PSTK
11	Cone	1	
12	Screw (Low Head)	1	
13	Bearing	1	
14	Screw (Socket Head)	3	
15	Top Plate	1	
16	Piston	1	
CYLINDER KIT			E5A2R-STH-CYLK
17	Cylinder	1	
18	Pin	2	
19	Bearing	1	
20	Retainer Ring	3	
21	Set Screw	1	

PARTS KITS

The *Repair Kit* contains common wear items for this product. Users are encouraged to stock one or more repair kits considering the number of units installed and the potential downtime if machinery on which the unit is installed is critical equipment. To obtain current pricing and lead time for parts kits, contact customer service.

orders@machiii.com

ADDITIONAL PRODUCT INFORMATION

For illustrated guides showing how Mach III products work, selection guidelines, product manuals, and installation and use recommendations:

<https://machiii.com/resources/how-our-products-work>

For information about how to order, return policy and warranty information:

<https://machiii.com/resources/how-to-order>



859-291-0849

machiii.com

engineering@machiii.com