

D5C3R-18H

Spring Engaged Friction Brake
NEMA 182TC, 184TC Frame Mount



NOT suitable for pulley output

Engagement/Disengagement	Spring/Air
Facing Type	High Coefficient
Torque – Dynamic	985 Pound Inches
Minimum Disengagement Pressure	55 PSI
Maximum Operating Pressure	80 PSI
Maximum RPM	1,750
Input Bore/Output Shaft	1.125 Inches
Air Volume New	0.12 Cubic Inches
Air Volume Worn	0.36 Cubic Inches
Finish	Aluminum
Open or Enclosed Construction	Enclosed
Shipping Weight	25 Pounds

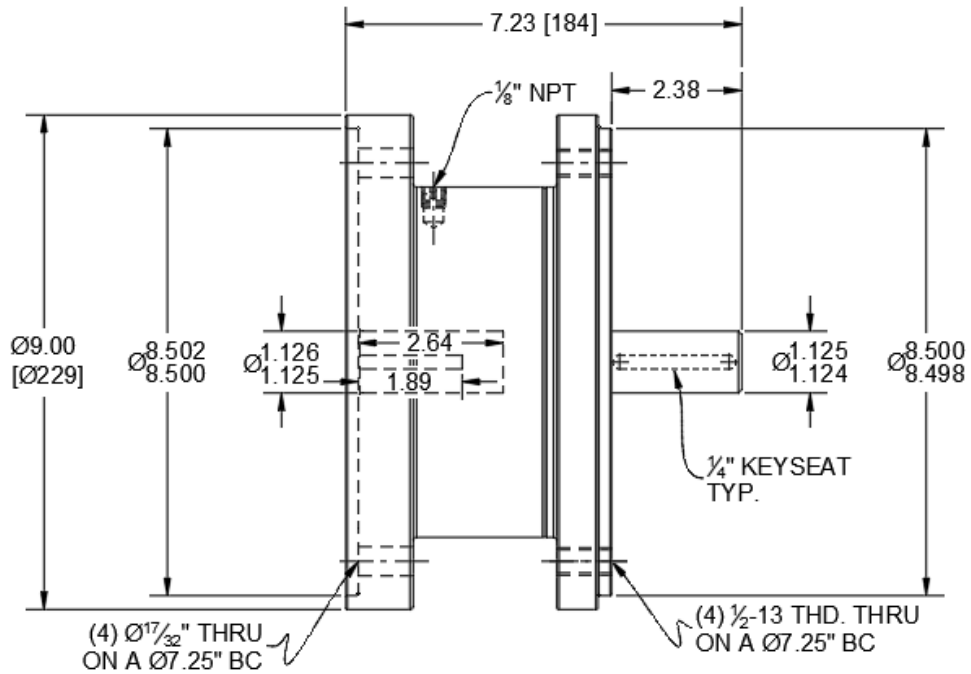

TORQUE vs. AIR PRESSURE

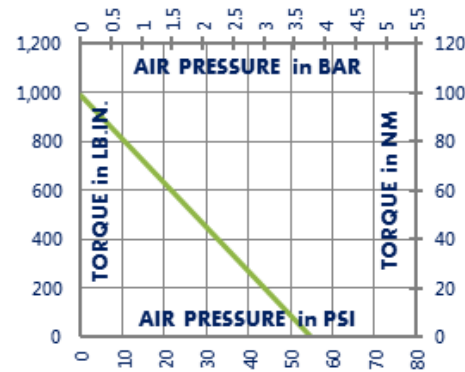

NEW vs. BURNISHED TORQUE

The torque output of a new friction brake or clutch can be up to 40% less than the published torque rating. To achieve full design torque, a unit must be cycled under load to burnish the friction surfaces. The exact number of cycles varies by application.

When calculating required torque always use a safety factor of 1.5 to 2. It is not recommended to select a product for use at its maximum rated torque for continuous duty.

PRODUCT SELECTION

Torque capacity is only one factor to consider when making a product selection. Ensure that you will have the right product for the job by contacting our engineering department for application review and selection assistance.



101 Cummings Drive
Walton, KY 41094 USA

859-291-0849

machiii.com

engineering@machiii.com

D5C3R-18H

Parts Diagram

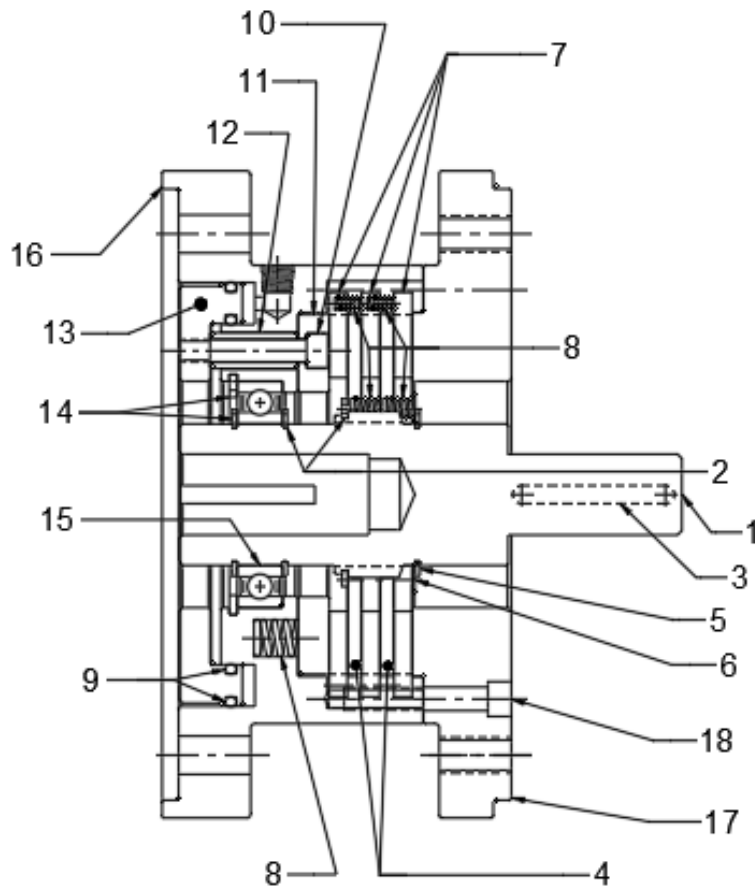

REF#	DESCRIPTION & PARTS INCLUDED	QUANTITY	KIT NUMBER
DRIVE HUB KIT			D5C3R-18H-HUBK
1	Drive Hub	1	
2	Retainer Ring	2	
3	Key Stock	1	
DRIVE DISC KIT			D5C3R-18H-DRDK
4	Drive Disc	2	
5	Retainer Ring	1	
6	Race	1	
REPAIR KIT			D5C3R-18H-RPRK
7	Friction Disc	3	
8	Coil Spring	21	
9	O-Ring	2	
PISTON KIT			D5F3H-STH-PSTK
10	Screw	3	
11	Pressure Plate	1	
12	Spacer	3	
13	Piston	1	
CYLINDER KIT			D5C3R-18H-CYLK
14	Retainer Ring	2	
15	Bearing	1	
16	Cylinder	1	
17	Adapter	1	
18	Screw	3	

PARTS KITS

The *Repair Kit* contains common wear items for this product. Users are encouraged to stock one or more repair kits considering the number of units installed and the potential downtime if machinery on which the unit is installed is critical equipment. To obtain current pricing and lead time for parts kits, contact customer service.

orders@machiii.com

ADDITIONAL PRODUCT INFORMATION

For illustrated guides showing how Mach III products work, selection guidelines, product manuals, and installation and use recommendations:

<https://machiii.com/resources/how-our-products-work>

For information about how to order, return policy and warranty information:

<https://machiii.com/resources/how-to-order>



859-291-0849

machiii.com

engineering@machiii.com