

D3C3R-14H

Spring Engaged Friction Brake
NEMA 143TC, 145TC Frame Mount



NOT suitable for pulley output

Engagement/Disengagement

Spring/Air

Facing Type

High Coefficient

Torque – Dynamic

222 Pound Inches

Minimum Disengagement Pressure

53 PSI

Maximum Operating Pressure

80 PSI

Maximum RPM

1,750

Input Bore/Output Shaft

.875 Inches

Air Volume New

0.07 Cubic Inches

Air Volume Worn

0.22 Cubic Inches

Finish

Aluminum

Open or Enclosed Construction

Enclosed

Shipping Weight

7 Pounds

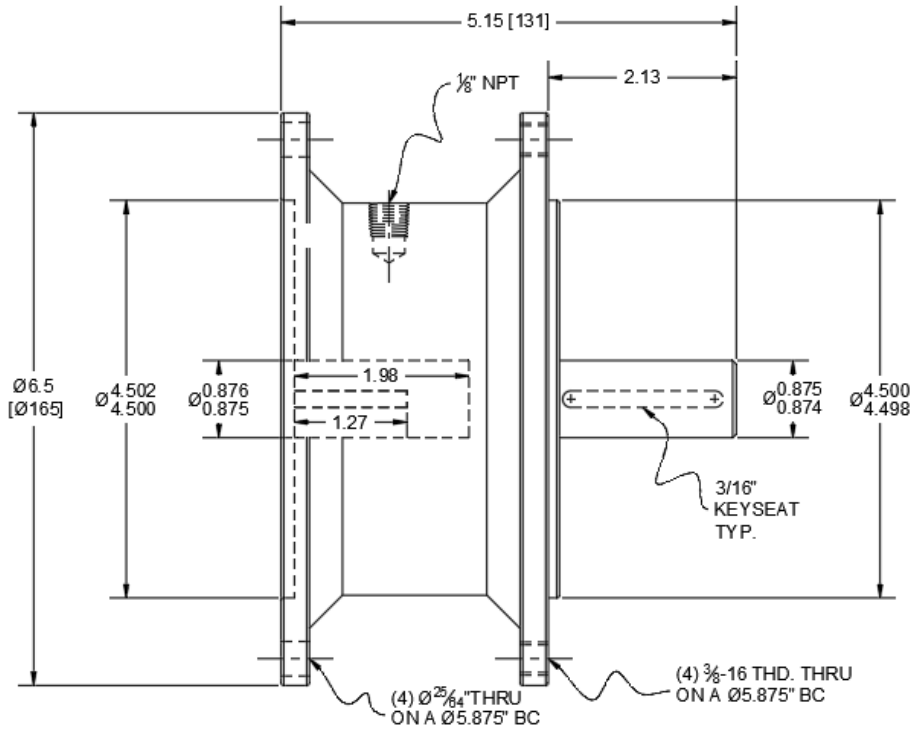

TORQUE vs. AIR PRESSURE

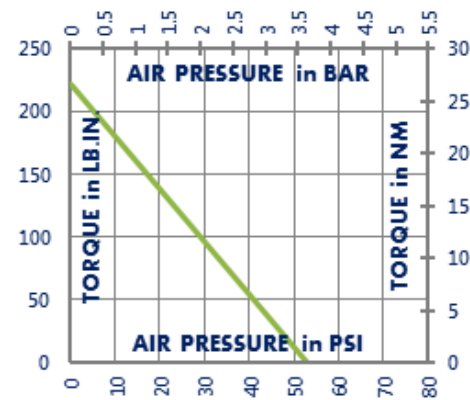

NEW vs. BURNISHED TORQUE

The torque output of a new friction brake or clutch can be up to 40% less than the published torque rating. To achieve full design torque, a unit must be cycled under load to burnish the friction surfaces. The exact number of cycles varies by application.

When calculating required torque always use a safety factor of 1.5 to 2. It is not recommended to select a product for use at its maximum rated torque for continuous duty.

PRODUCT SELECTION

Torque capacity is only one factor to consider when making a product selection. Ensure that you will have the right product for the job by contacting our engineering department for application review and selection assistance.



101 Cummings Drive
Walton, KY 41094 USA

859-291-0849

machiii.com

engineering@machiii.com

D3C3R-14H

Parts Diagram

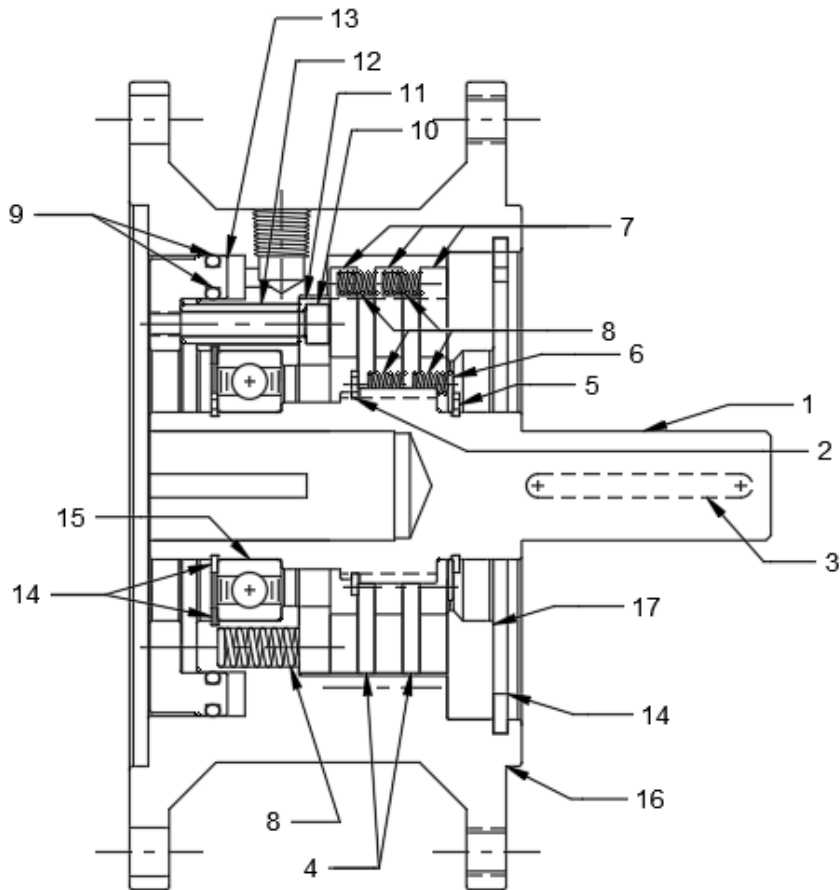

REF#	DESCRIPTION & PARTS INCLUDED	QUANTITY	KIT NUMBER
	DRIVE HUB KIT		D3C3R-14H-HUBK
1	Drive Hub	1	
2	Retainer Ring	1	
3	Key Stock	1	
	DRIVE DISC KIT		D3C3R-14H-DRDK
4	Drive Disc	2	
5	Retainer Ring	1	
6	Race	1	
	REPAIR KIT		D3C3R-14H-RPRK
7	Friction Disc	3	
8	Coil Spring	27	
9	O-Ring	2	
	PISTON KIT		D3F3H-STH-PSTK
10	Screw	3	
11	Pressure Plate	1	
12	Spacer	3	
13	Piston	1	
	CYLINDER KIT		D3C3H-STH-CYLK
14	Retainer Ring	3	
15	Bearing	1	
16	Cylinder	1	
17	Top Plate	1	

PARTS KITS

The *Repair Kit* contains common wear items for this product. Users are encouraged to stock one or more repair kits considering the number of units installed and the potential downtime if machinery on which the unit is installed is critical equipment. To obtain current pricing and lead time for parts kits, contact customer service.

orders@machiii.com

ADDITIONAL PRODUCT INFORMATION

For illustrated guides showing how Mach III products work, selection guidelines, product manuals, and installation and use recommendations:

<https://machiii.com/resources/how-our-products-work>

For information about how to order, return policy and warranty information:

<https://machiii.com/resources/how-to-order>



859-291-0849

machiii.com

engineering@machiii.com