

D2C2R-48H

Spring Engaged Friction Brake
NEMA 48 Frame Mount



NOT suitable for pulley output

Engagement/Disengagement

Spring/Air

Facing Type

High Coefficient

Torque – Dynamic

73 Pound Inches

Minimum Disengagement Pressure

60 PSI

Maximum Operating Pressure

80 PSI

Maximum RPM

1,750

Input Bore/Output Shaft

0.500

Air Volume New

0.02 Cubic Inches

Air Volume Worn

0.33 Cubic Inches

Finish

Aluminum

Open or Enclosed Construction

Enclosed

Shipping Weight

2 Pounds

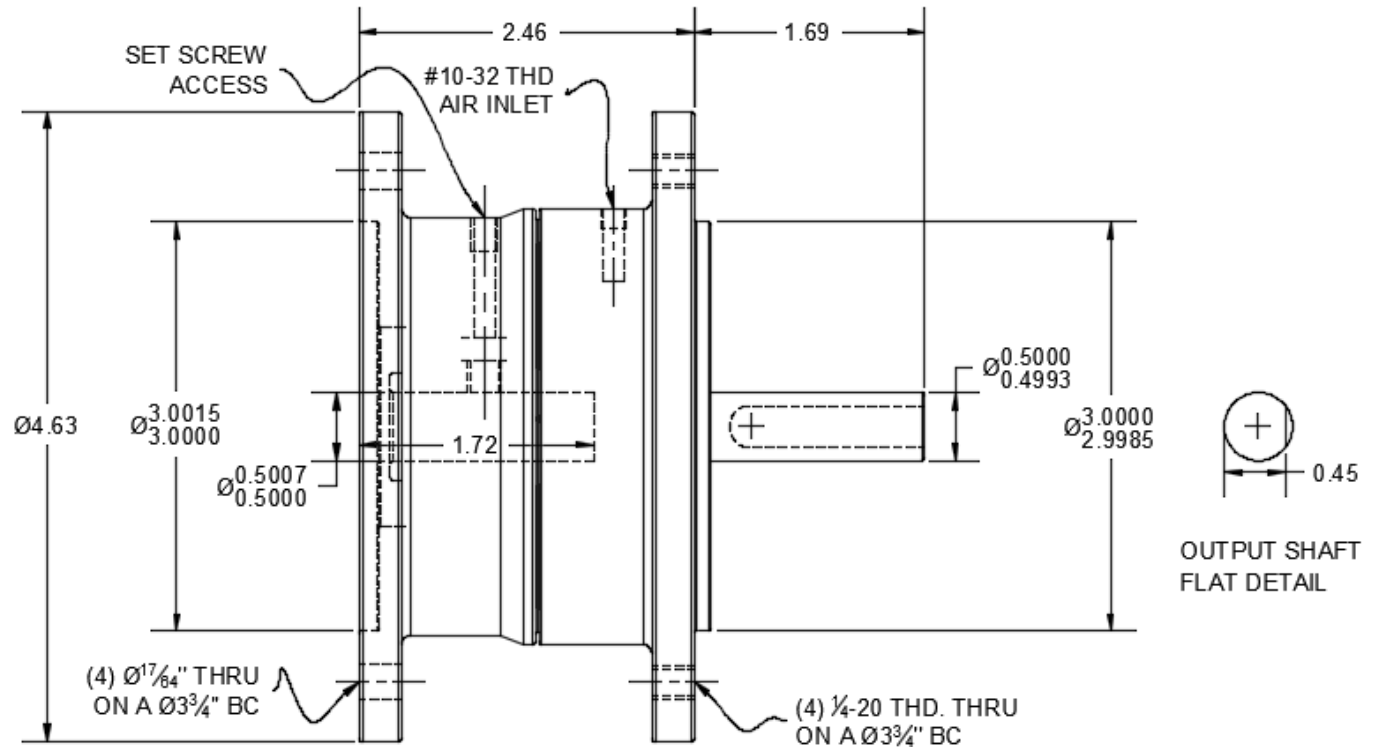

TORQUE vs. AIR PRESSURE

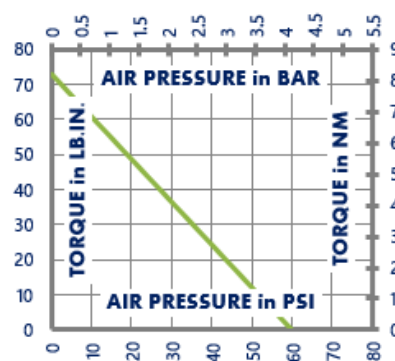

NEW vs. BURNISHED TORQUE

The torque output of a new friction brake or clutch can be up to 40% less than the published torque rating. To achieve full design torque, a unit must be cycled under load to burnish the friction surfaces. The exact number of cycles varies by application.

When calculating required torque always use a safety factor of 1.5 to 2. It is not recommended to select a product for use at its maximum rated torque for continuous duty.

PRODUCT SELECTION

Torque capacity is only one factor to consider when making a product selection. Ensure that you will have the right product for the job by contacting our engineering department for application review and selection assistance.



1580 Lake Street
Elmira, NY 14901 USA

859-291-0849

machiii.com

engineering@machiii.com

D2C2R-48H

Parts Diagram

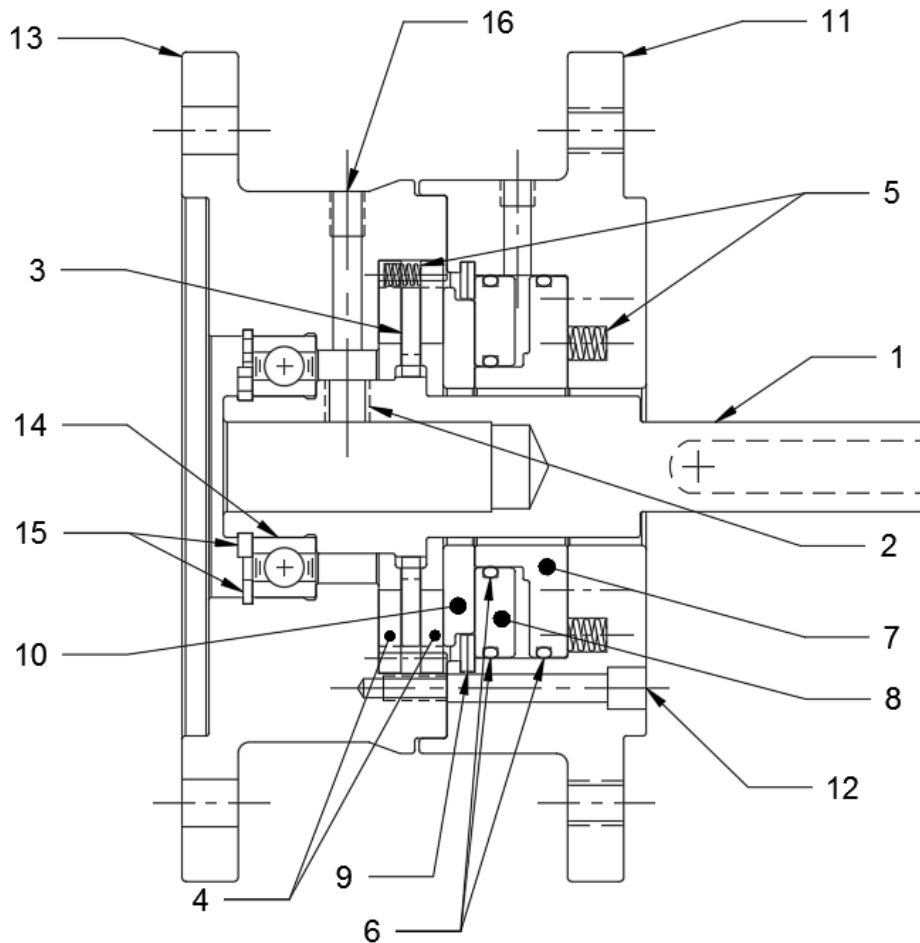

REF#	DESCRIPTION & PARTS INCLUDED	QUANTITY	KIT NUMBER
DRIVE HUB KIT			D2C2R-48H-HUBK
1	Drive Hub	1	
2	Set Screw	1	
DRIVE DISC			D2C2R-42H-P005
REPAIR KIT			D2C2R-48H-RPRK
4	Friction Disc	2	
5	Coil Spring	31	
6	O-Ring	3	
PISTON KIT			D2C2R-42H-PSTK
7	Spring Retainer	1	
8	Piston	1	
9	Retainer Ring	1	
10	Spacer	1	
CYLINDER KIT			D2C2R-42H-CYLK
11	Cylinder	1	
12	Screw	3	
ADAPTER KIT			D2C2R-42H-APDK
13	Adapter	1	
14	Bearing	1	
15	Retainer Ring	2	
16	Set Screw	1	

PARTS KITS

The *Repair Kit* contains common wear items for this product. Users are encouraged to stock one or more repair kits considering the number of units installed and the potential downtime if machinery on which the unit is installed is critical equipment. To obtain current pricing and lead time for parts kits, contact customer service.

orders@machiii.com

ADDITIONAL PRODUCT INFORMATION

For illustrated guides showing how Mach III products work, selection guidelines, product manuals, and installation and use recommendations:

<https://machiii.com/resources/how-our-products-work>

For information about how to order, return policy and warranty information:

<https://machiii.com/resources/how-to-order>



859-291-0849

machiii.com

engineering@machiii.com