

CBA2K-STH

Air Engaged Friction Clutch
Through Shaft Bored, Pilot Mount



Minimum Sprocket Sizes

Chain Size	60	80	100	120
Minimum Teeth	43	33	27	24

Engagement/Disengagement

Air/Spring

Facing Type

High Coefficient

Torque @ 80 PSI – Dynamic

21,204 Pound Inches

Minimum Engagement Pressure

4 PSI

Maximum Operating Pressure

80 PSI

Maximum RPM

950

Bore Range with Standard Keyway

2.125 (54) to 3.500 (95) Inches (mm)

Air Volume New

6.26 Cubic Inches

Air Volume Worn

23.65 Cubic Inches

Finish

Aluminum

Open or Enclosed Construction

Open

Shipping Weight

200 Pounds

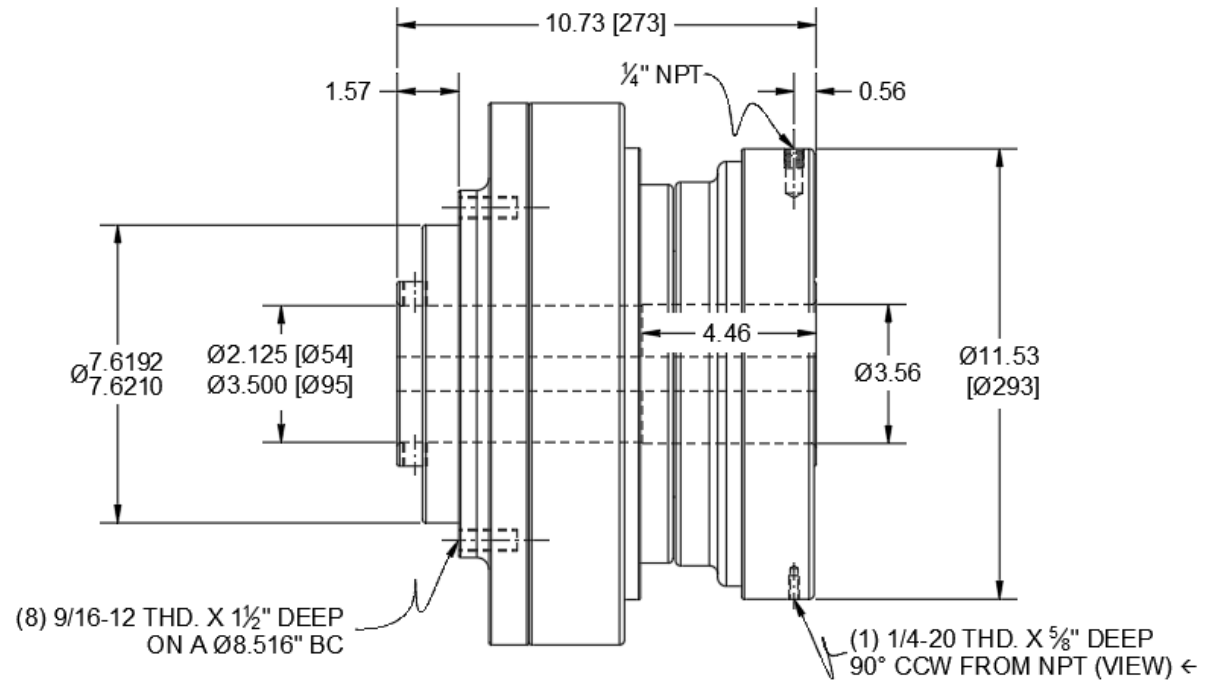

TORQUE vs. AIR PRESSURE

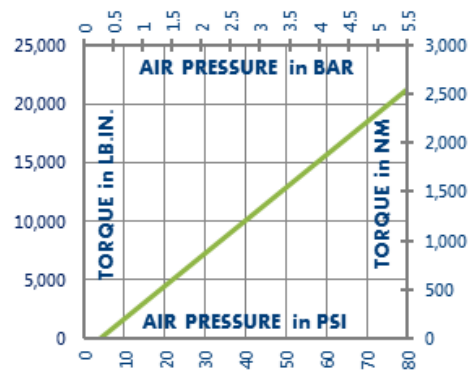

NEW vs. BURNISHED TORQUE

The torque output of a new friction brake or clutch can be up to 40% less than the published torque rating. To achieve full design torque, a unit must be cycled under load to burnish the friction surfaces. The exact number of cycles varies by application.

When calculating required torque always use a safety factor of 1.5 to 2. It is not recommended to select a product for use at its maximum rated torque for continuous duty.

PRODUCT SELECTION

Torque capacity is only one factor to consider when making a product selection. Ensure that you will have the right product for the job by contacting our engineering department for application review and selection assistance.



101 Cummings Drive
Walton, KY 41094 USA

859-291-0849

machiii.com

engineering@machiii.com

CBA2K-STH

Parts Diagram

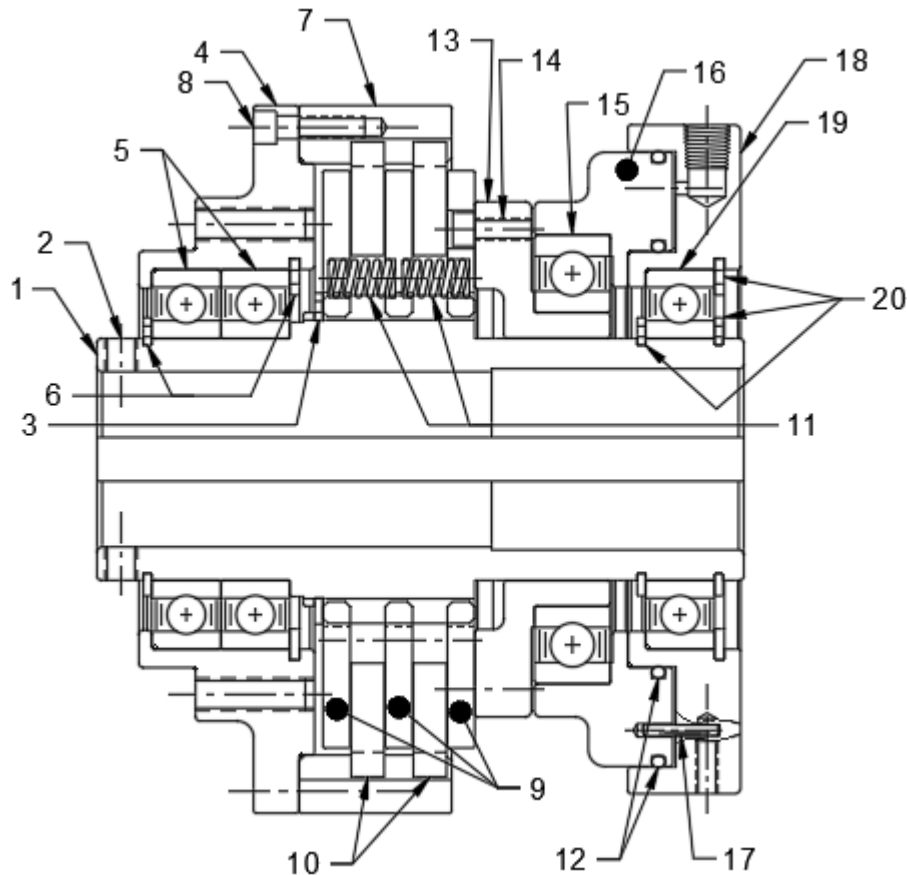

REF#	DESCRIPTION & PARTS INCLUDED	QUANTITY	KIT NUMBER
	DRIVE HUB KIT		CBA2K-STH-HUBK
1	Drive Hub	1	<i>Specify Bore Size When Ordering</i>
2	Set Screw	2	
3	Retainer Ring	1	
	SLEEVE KIT		CBA2K-STH-SLVK
4	Sleeve	1	
5	Bearing	2	
6	Retainer Ring	2	
7	Ring Gear	1	
8	Screw	9	
	DRIVE DISC KIT		CBA2K-STH-DRDK
9	Drive Disc	3	
	REPAIR KIT		CBA2K-STH-RPRK
10	Friction Disc	2	
11	Coil Spring	12	
12	O-Ring	2	
	PISTON KIT		CBA2K-STH-PSTK
13	Cone	1	
14	Screw	1	
15	Bearing	1	
16	Piston	1	
	CYLINDER KIT		CBA2K-STH-CYLK
17	Pin	2	
18	Cylinder	1	
19	Bearing	1	
20	Retainer Ring	3	

PARTS KITS

The *Repair Kit* contains common wear items for this product. Users are encouraged to stock one or more repair kits considering the number of units installed and the potential downtime if machinery on which the unit is installed is critical equipment. To obtain current pricing and lead time for parts kits, contact customer service.

orders@machiii.com

ADDITIONAL PRODUCT INFORMATION

For illustrated guides showing how Mach III products work, selection guidelines, product manuals, and installation and use recommendations:

<https://machiii.com/resources/how-our-products-work>

For information about how to order, return policy and warranty information:

<https://machiii.com/resources/how-to-order>



859-291-0849

machiii.com

engineering@machiii.com