

C2A2R-STH

Air Engaged Friction Clutch
Through Shaft Bored, Pilot Mount



Minimum Sprocket Sizes

Chain Size	25	35	40
Minimum Teeth	32	22	17

Engagement/Disengagement

Air/Spring

Facing Type

High Coefficient

Torque @ 80 PSI – Dynamic

190 Pound Inches

Minimum Engagement Pressure

2.5 PSI

Maximum Operating Pressure

80 PSI

Maximum RPM

1,750

Bore Range with Standard Keyway

0.313 (7) to 0.500 (12) Inches (mm)

Air Volume New

0.10 Cubic Inches

Air Volume Worn

0.23 Cubic Inches

Finish

Aluminum

Open or Enclosed Construction

Open

Shipping Weight

1 Pounds

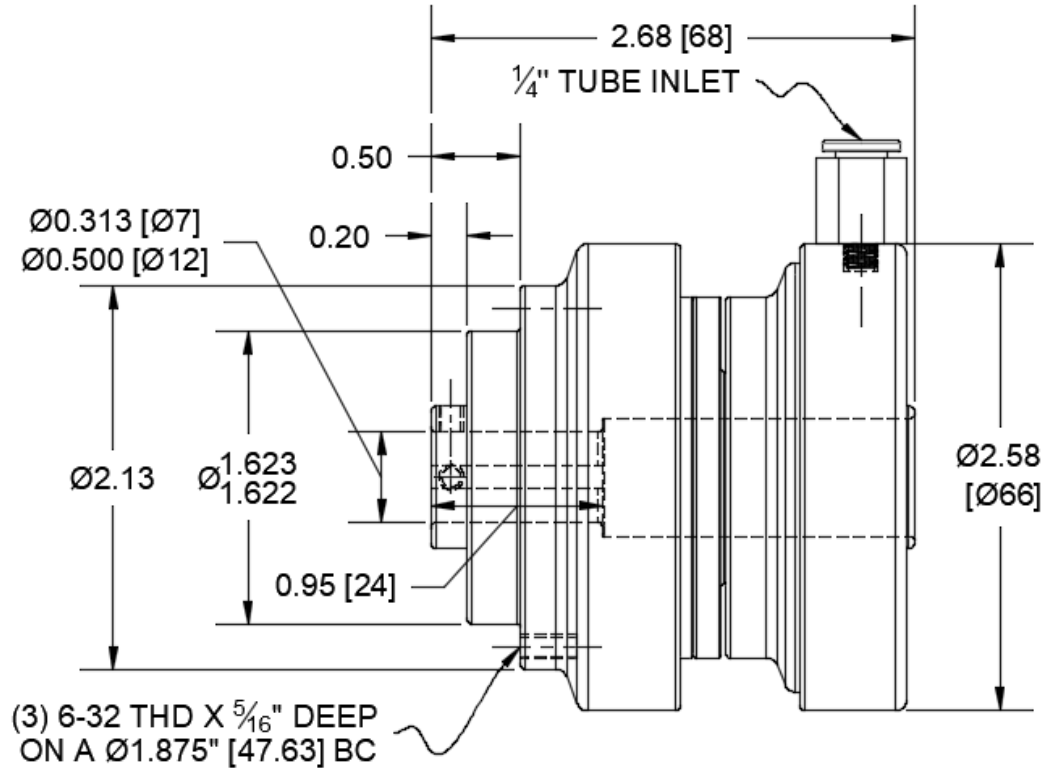

TORQUE vs. AIR PRESSURE

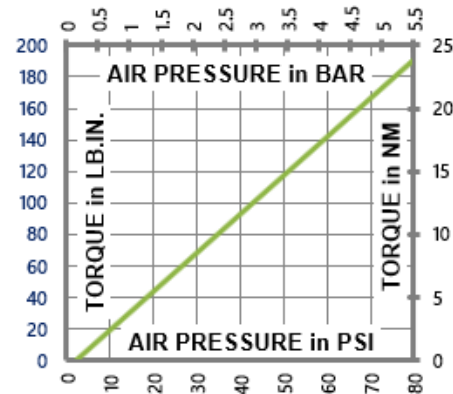

NEW vs. BURNISHED TORQUE

The torque output of a new friction brake or clutch can be up to 40% less than the published torque rating. To achieve full design torque, a unit must be cycled under load to burnish the friction surfaces. The exact number of cycles varies by application.

When calculating required torque always use a safety factor of 1.5 to 2. It is not recommended to select a product for use at its maximum rated torque for continuous duty.

PRODUCT SELECTION

Torque capacity is only one factor to consider when making a product selection. Ensure that you will have the right product for the job by contacting our engineering department for application review and selection assistance.



1580 Lake Street
Elmira, NY 14901 USA

859-291-0849

machiii.com

engineering@machiii.com

C2A2R-STH

Parts Diagram

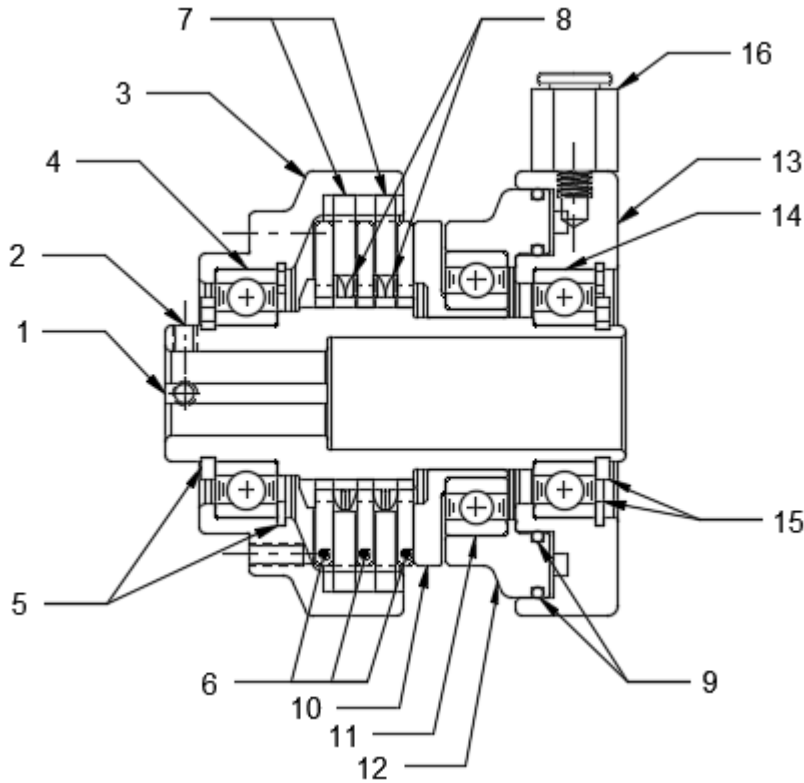

REF#	DESCRIPTION & PARTS INCLUDED	QUANTITY	KIT NUMBER
	DRIVE HUB KIT		C2A2R-STH-HUBK
1	Drive Hub	1	<i>Specify Bore Size When Ordering</i>
2	Set Screw	2	
	SLEEVE KIT		C2A2R-STH-SLVK
3	Sleeve	1	
4	Bearing	1	
5	Retainer Ring	2	
	DRIVE DISC KIT		C2A2R-STH-DRDK
6	Drive Disc	3	
	REPAIR KIT		C2A2R-STH-RPRK
7	Friction Disc	2	
8	Wave Spring	2	
9	O-Ring	2	
	PISTON KIT		C2A2R-STH-PSTK
10	Cone	1	
11	Bearing	1	
12	Piston	1	
	CYLINDER KIT		C2A2R-STH-CYLK
13	Cylinder	1	
14	Bearing	1	
15	Retainer Ring	2	
16	AIR SEAL	1	RSEAL-034

PARTS KITS

The *Repair Kit* contains common wear items for this product. Users are encouraged to stock one or more repair kits considering the number of units installed and the potential downtime if machinery on which the unit is installed is critical equipment. To obtain current pricing and lead time for parts kits, contact customer service.

orders@machiii.com

ADDITIONAL PRODUCT INFORMATION

For illustrated guides showing how Mach III products work, selection guidelines, product manuals, and installation and use recommendations:

<https://machiii.com/resources/how-our-products-work>

For information about how to order, return policy and warranty information:

<https://machiii.com/resources/how-to-order>



859-291-0849

machiii.com

engineering@machiii.com