

38FM-ULOW

Tension Control Clutch

SensiFlex® Foot Mount



Engagement/Disengagement

Air/Spring

Facing Type

Ultra-Low Coefficient

Torque @ 80 PSI – Dynamic

36 Pound Inches

Minimum Engagement Pressure

5.5 – 6.5 PSI

Maximum Operating Pressure

80 PSI

Maximum RPM

1,750

Input/Output Shaft with Standard Keyway

0.500 Inches

Air Volume New

0.08 Cubic Inches

Air Volume Worn

0.43 Cubic Inches

Finish

Iron

Open or Enclosed Construction

Open

Shipping Weight

6 Pounds

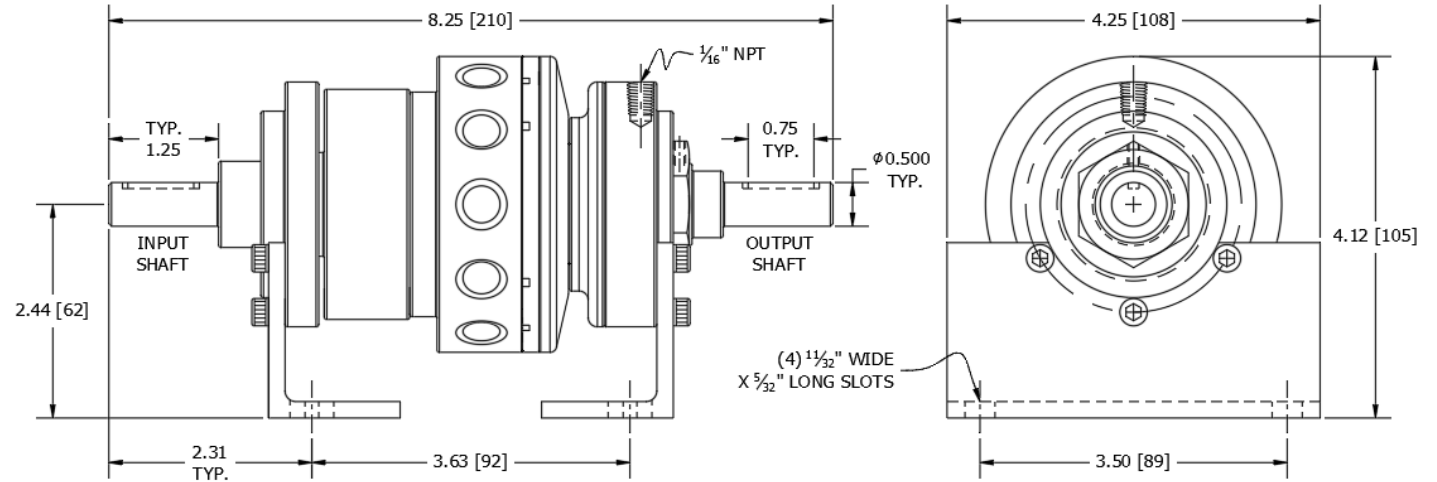

Note:

This clutch has a designated input and output shaft. Thermal-Horsepower ratings are only valid if the clutch is oriented in this manner.

CONTINUOUS THERMAL HORSEPOWER

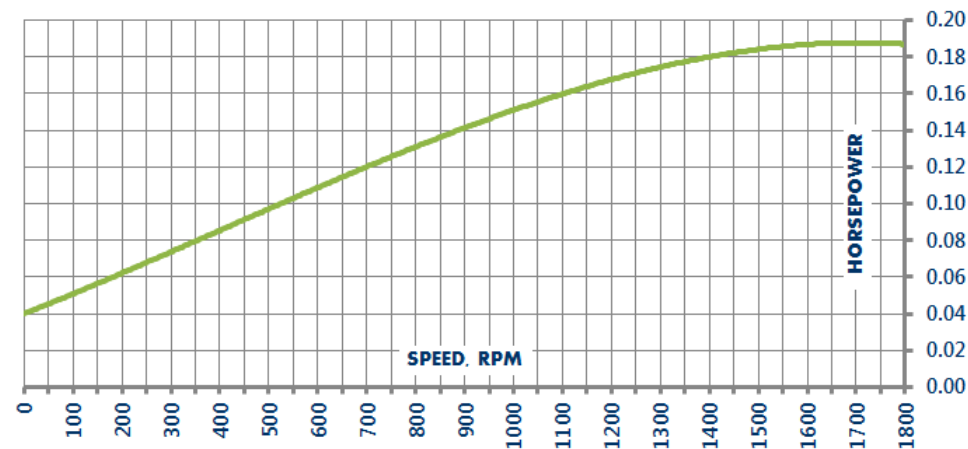

1580 Lake Street
 Elmira, NY 14901 USA
 859-291-0849
 machiii.com

engineering@machiii.com

38FM-ULOW

Parts Diagram

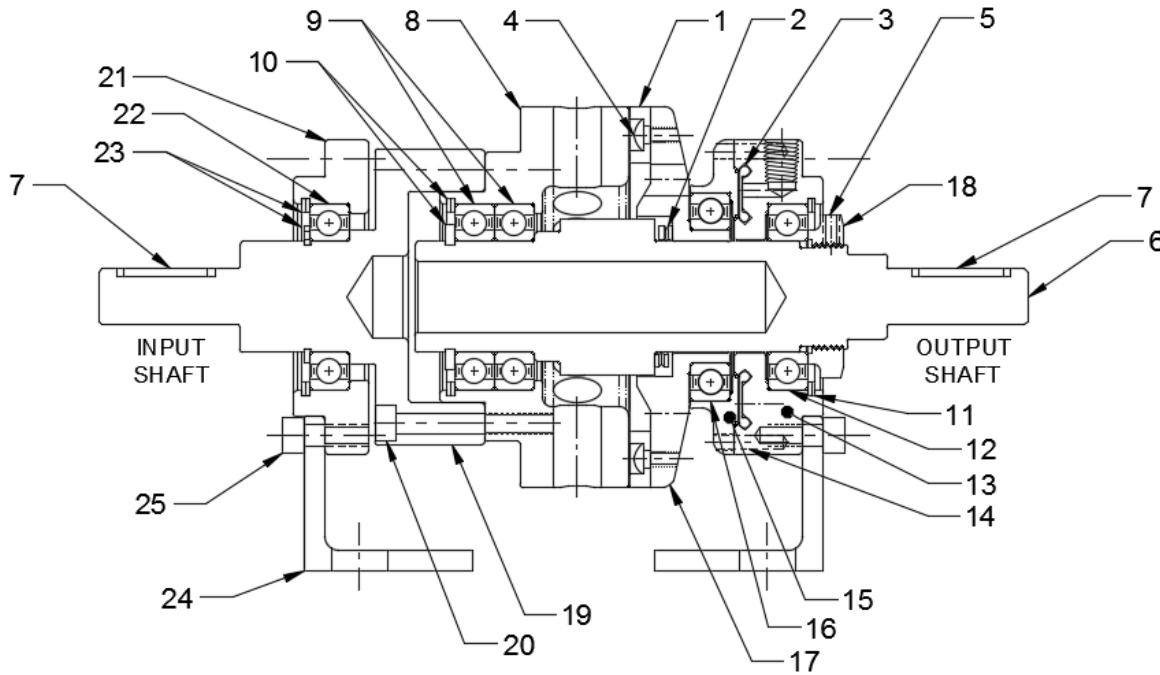

REF#	DESCRIPTION & PARTS INCLUDED	QUANTITY	KIT NUMBER
	REPAIR KIT		38FM-ULOW-RPRK
1	Friction Disc	1	
2	Wave Spring	1	
3	Diaphragm	1	
4	Screw	3	
5	Nylon Point Set Screw	1	
	DRIVE HUB KIT		38FM-HUBK
6	Drive Hub	1	
7	Key Stock	1	
	SLEEVE KIT		38PI-SLVK
8	Sleeve	1	
9	Bearing	2	
10	Retainer Ring	2	
	CYLINDER KIT		38FM-CYLK
11	Retainer Ring	1	
12	Bearing	1	
13	Cylinder	1	
14	Pin	2	
	PISTON KIT		38PI-PSTK
15	Piston	1	
16	Bearing	1	
17	Drive Disc	1	
	FACING KIT		38FM-ULOW-FCGK
1	Friction Disc	1	
4	Screw	3	
5	Nylon Point Set Screw	1	
	NUT KIT		38PI-NUTK
18	Nut	1	
5	Nylon Point Set Screw	1	
	COUPLING KIT		38FM-CPLK
19	Coupling	1	
20	Screw	3	
7	Key Stock	1	
	ADAPTER KIT		38FM-ADPK
21	Adapter	1	
22	Bearing	1	
23	Retainer Ring	2	
	BRACKET KIT		38FM-BRKK
24	Bracket	2	
25	Screw	6	

PARTS KITS

The *Repair Kit* contains common wear items for this product. Users are encouraged to stock one or more repair kits considering the number of units installed and the potential downtime if machinery on which the unit is installed is critical equipment. To obtain current pricing and lead time for parts kits, contact customer service.

orders@machiii.com

ADDITIONAL PRODUCT INFORMATION

For illustrated guides showing how Mach III products work, selection guidelines, product manuals, and installation and use recommendations:

<https://machiii.com/resources/how-our-products-work>

For information about how to order, return policy and warranty information:

<https://machiii.com/resources/how-to-order>



859-291-0849

machiii.com

engineering@machiii.com