

Mounting Sprockets and Pulleys On Pilot Style Clutches

Considerations & Guidelines

Clutches are commonly connected to a drive system through roller chains and belting. This requires that a sprocket or pulley be mounted directly to the clutch. A pilot style clutch is made for this purpose; providing a projection onto which the sprocket or pulley will seat and a series of tapped holes along a bolt circle where the sprocket or pulley will be attached.



Photo 1: A Comparison of Clutch Styles

This document discusses the factors which must be taken into consideration when selecting, machining and mounting a sprocket or pulley for a pilot style clutch. When proper mounting and installation procedures are followed, optimal performance and wear life are assured.

Service (Safety) Factor

When selecting a clutch for an application, a service factor must be taken into consideration. A service factor (also known as a safety factor) is the overload capacity that a component can handle without failing. With respect to clutches, this translates to the total load the clutch can handle without slipping. A service factor of 1.5 to 2 (50% to 100% more torque than is required to drive the load) is recommended by most clutch manufacturers.

Example:

Torque required to drive the load = 500 pound inches

1.5 Service Factor = 500 x 1.5 = 750 pound inches

2.0 Service Factor = 500 x 2.0 = 1000 pound inches

The clutch selected for the application should have a torque capacity of between 750 and 1000 pound inches.

Sometimes overlooked is whether the roller chain or belting that will be connected to the clutch has the same service factor. When selecting the chain or belting, system designers must apply the same service factor or greater to the chain or belt selection as was applied to the clutch selection. Roller chain and belting manufacturers are the best resource for determining the horsepower ratings of their products.

Chain Clearance

The sprocket must be of an adequate diameter to provide clearance between the chain and the body of the clutch. Figure 1 shows the dimensions that must be taken into consideration. Clutch manufacturers typically make this easy for the customer by providing references that list minimum tooth counts for a given chain size for the clutches in their product line. An example of this is shown in Figure 2.

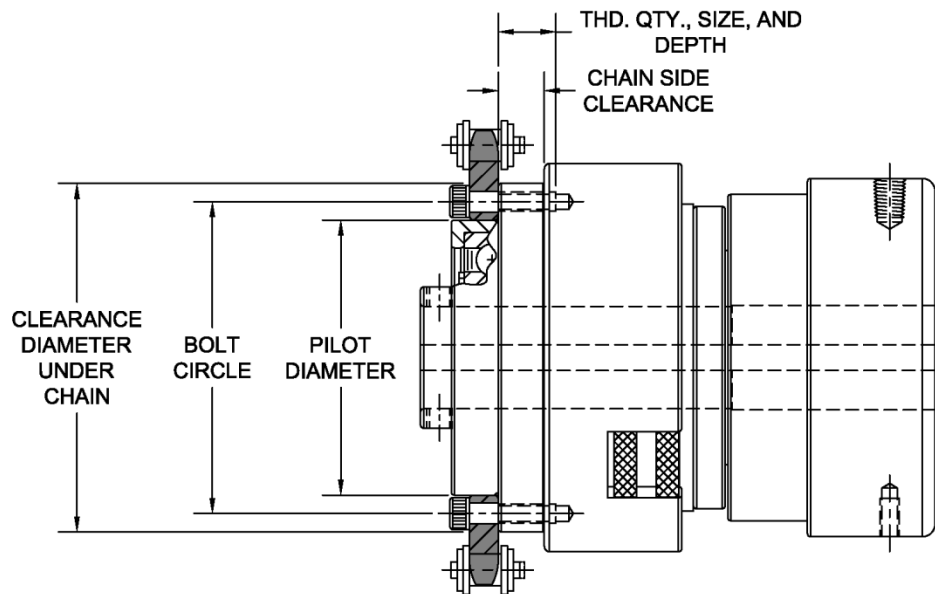

Figure 1: Dimensions Needed for Determining Adequate Chain Clearance

Pilot Diameter "H" Dimension	Minimum "A" Type Sprockets						
	35 Chain	40 Chain	50 Chain	60 Chain	80 Chain	100 Chain	120 Chain
1.594	23	19	16	14			
1.875	26	20	17	15			
2.187	29	23	19	17			
2.375	30	23	20	17			
2.531			22	19	15		
2.656			22	19	16		
2.687	33	25	21	18			

Figure 2: Sample Minimum Sprocket Chart

Load

To properly mount a sprocket or pulley on the pilot of a clutch, the chain or belt load must be taken into consideration. Mounting a single or “A” type sprocket is straightforward in this regard, for it is simply bored to a slide fit over the pilot diameter and is drilled to match the bolt size and pattern of the supplied clutch. Multiple strand sprockets, “B” type sprockets, timing belt and v-belt pulleys, on the other hand, must be machined so that the chain or belt load is centered over the pilot bearings or pilot bushing.

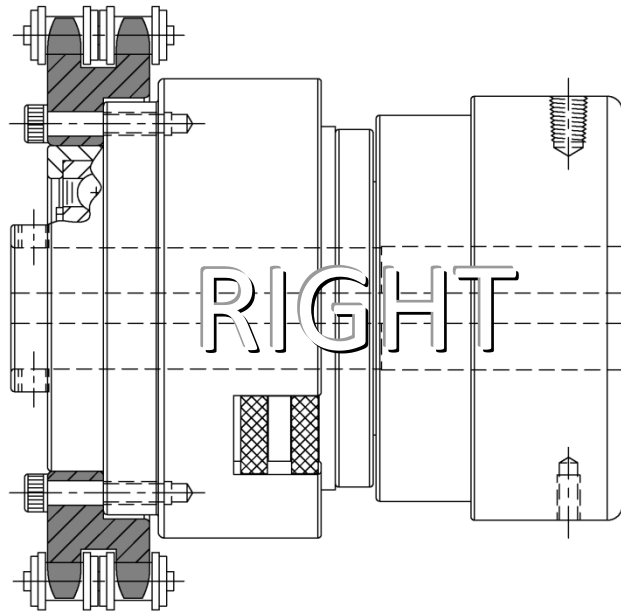

Figure 3A: Properly Mounted Double Strand Sprocket

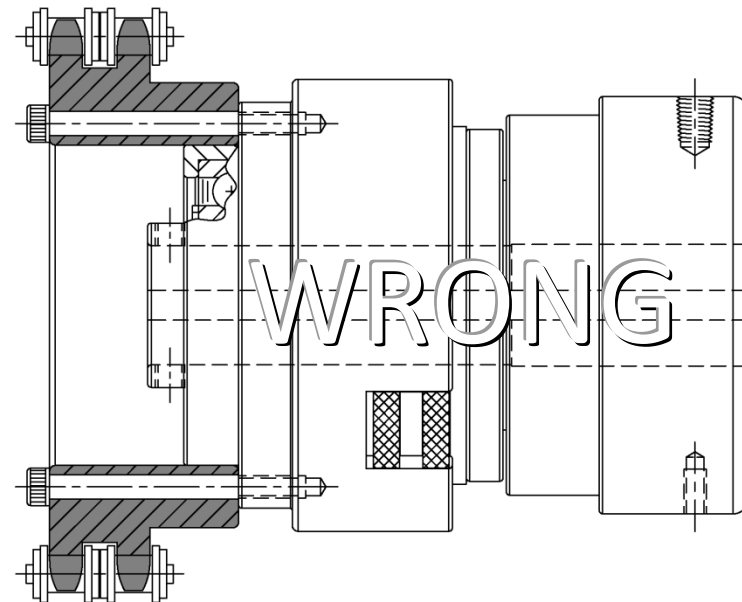

Figure 3B: Improperly Mounted Double Strand Sprocket

Figure 3A illustrates a double strand sprocket which has been properly machined for and mounted to the clutch pilot. The load is centered over the ball bearing. The mounting method shown in Figure 3B, however, produces an **overhung load**. Operating a clutch with an overhung load will cause the bearings or bushing in the pilot of the clutch to wear prematurely. Overhung loads can bind the internal components of a clutch causing delay in engagement and disengagement of the clutch or preventing engagement or disengagement altogether.

Load (continued)

Another symptom of overhung load can be seen in Photo 2. A pulley was installed on the pilot of this clutch as illustrated below in Figure 4A. The resulting overhung load caused it to move axially or “walk” off the shaft, smashing the rotary air union against the machine frame. The remedy for this problem is a modified clutch with an extended pilot as shown in Figure 4B. The extended pilot will provide proper support for the pulley by centering the load over the bronze bushing in the pilot.



Photo 2: Clutch Operating with Overhung Load

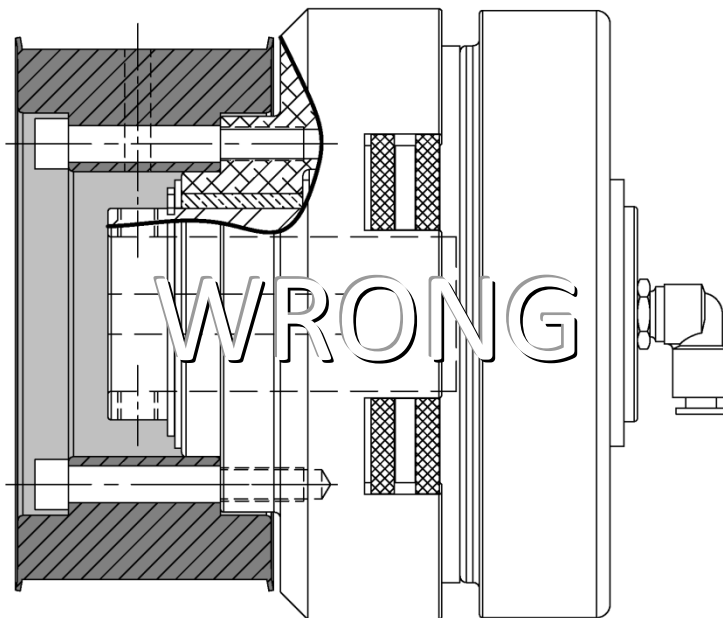

Figure 4A: Improperly Mounted Pulley – Overhung Load

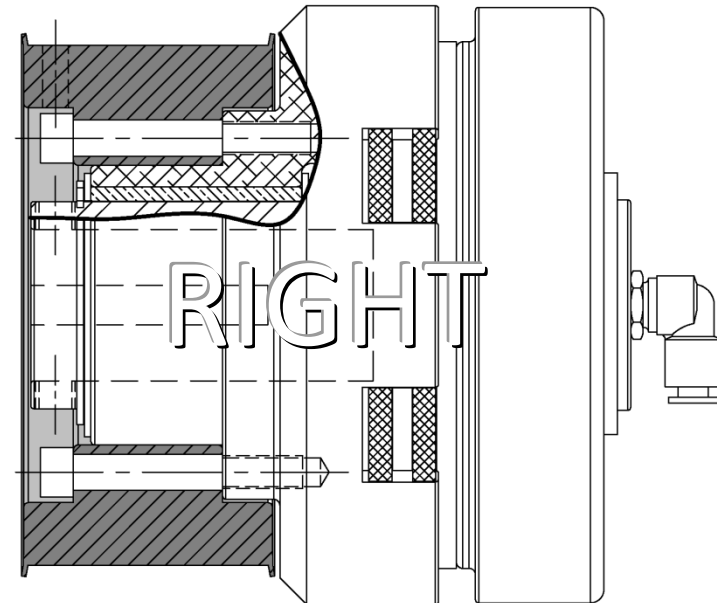

Figure 4B: Pulley Mounted Correctly – Load Centered Over Bushing

Attachment

As important as properly centering the belt or chain in assuring proper operation and maximum wear life is properly attaching the sprocket or pulley to the clutch. Clutch manufacturers will typically provide threaded holes on the face of the pilot of their clutches to facilitate the mounting of sprockets and pulleys. The customer should use screws of the thread size and length corresponding to the threaded hole provided by the clutch manufacturer.

Screw Length

The length of the screw used to attach the sprocket or pulley is important for two reasons. First, as illustrated in Figure 5A, an excessively long bolt used in a [through hole](#) can interfere with the movement of the drive plates. In this example, the clutch would either be stuck in a fully or partially engaged position. If a [blind hole](#) is provided an excessively long bolt will bottom out in the hole and fail to clamp the sprocket or pulley tightly.

Second, a screw as shown in Figure 5B that is not long enough would have inadequate thread engagement and the threads may shear under load. It is recommended that bolts be of sufficient length to utilize the full extent of the threads provided by the clutch manufacturer without exceeding the length of the hole.

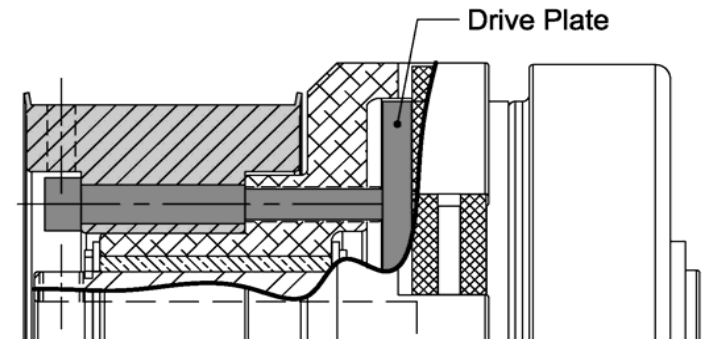

Figure 5A: Screw Interfering With Clutch Operation

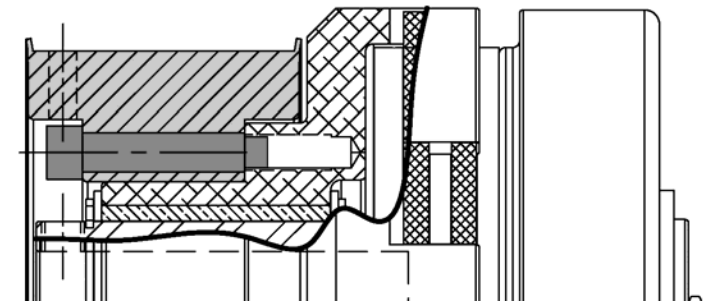

Figure 5B: Inadequate Thread Engagement

Attachment (continued)

Screw Tightening

The screws which attach a sprocket or pulley to the pilot of a clutch should always be tightened sequentially using a torque wrench. The screws should be tightened to the torque specifications of the screw manufacturer. Refer to the resource list on Page 11 for reference links.

Screw Breakage

Screw breakage after the clutch is put into operation is an obvious sign of a problem. To identify the problem, begin with identifying the type of breakage:

The load has exceeded the [Shear Strength](#) of the Screw

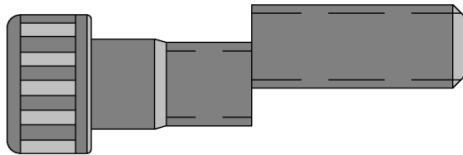

Possible Causes

- Inadequately sized screws
- Inadequate number of screws

The load has exceeded the [Tensile Strength](#) of the Screw

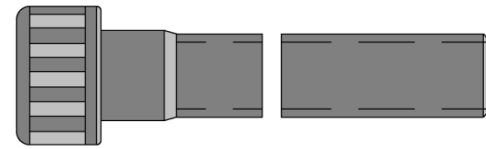

Possible Causes

- Over-tightened (over-torqued) screws
- Excessive side load on the sprocket or pulley

Alignment

Key to assuring maximum life of the clutch and the sprocket or pulley is proper alignment between the sprocket or pulley mounted on the pilot of the clutch and the mating sprocket or pulley in the drive system. Similar to overhung load, misalignment as shown in Figure 5A will produce premature wear of the bearings or bushing in the pilot of the clutch and axial movement of the clutch (walking off the shaft). Additionally, the teeth of an improperly aligned sprocket will also wear prematurely as seen in Photo 3.

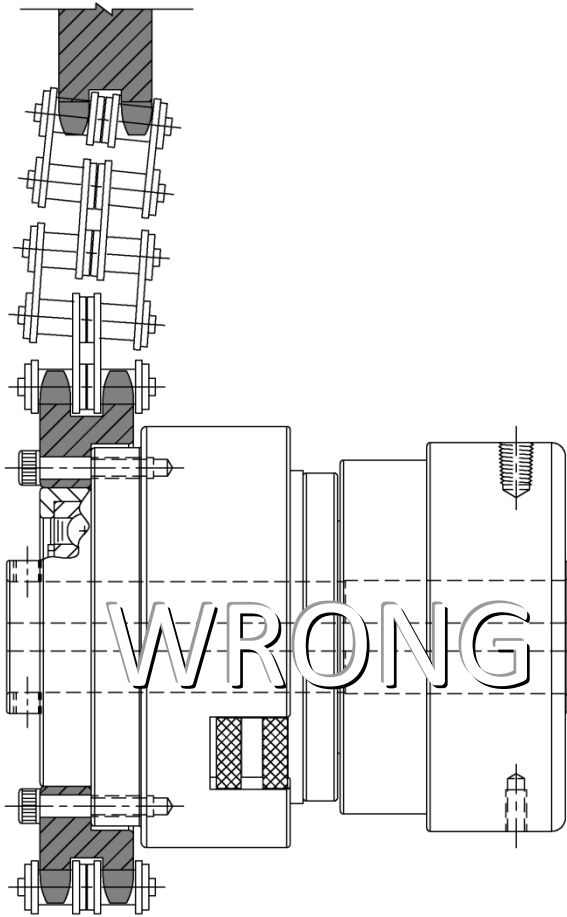

Figure 5A: Misaligned Sprockets

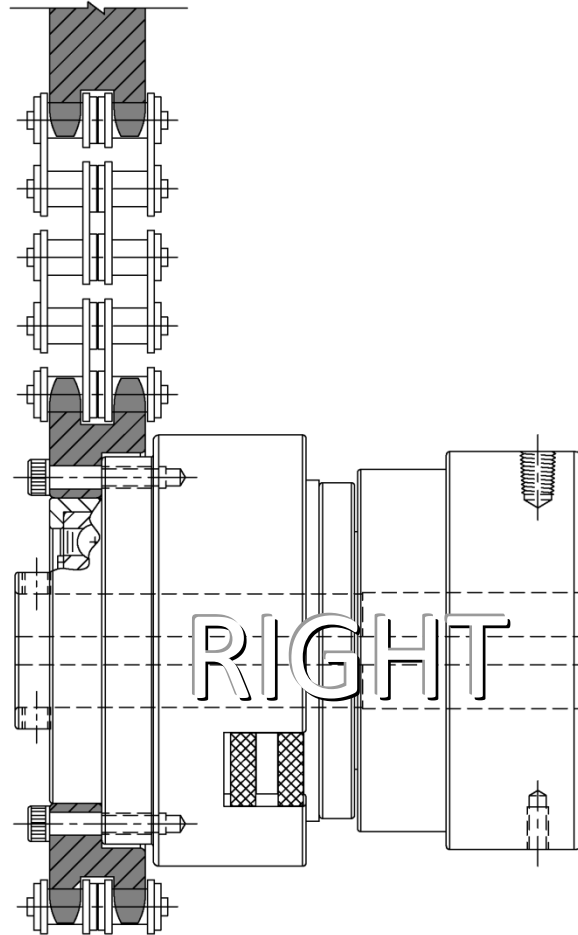

Figure 5B: Aligned Sprockets



Photo 3: Sprocket Worn from Misalignment

Chain and Belt Tension

The final factor in successful installation of a clutch with a pilot mounted sprocket or pulley is the use of proper chain or belt tension. If chain or belt tension is excessive, the bushing or bearings in the clutch will wear prematurely. Excessive tension can also cause clutches to continue driving when disengaged. If chains or belts are too loose they will not remain connected to the sprocket or pulley and will wear prematurely. Figure 6 below shows an example of a properly tensioned roller chain.

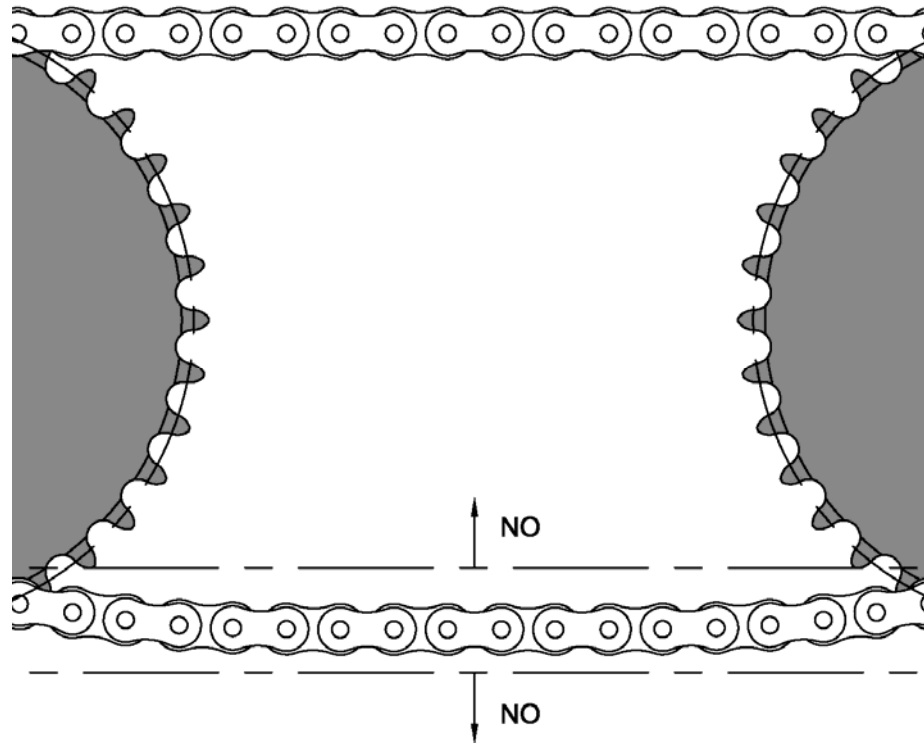

Figure 6: Illustration of Proper Chain Tension

Roller chain and belting manufacturers are the best resource for guidelines on proper tensioning and chain length adjustment procedures. See the reference list on Page 11 for suggested links.

Summary of Considerations & Guidelines for Mounting Sprockets and Pulleys on Clutches

- **Service (Safety) Factor**

The same service factor or greater must be applied to the chain or belt selection as was applied to the clutch selection.

- **Chain Clearance**

The sprocket must be of an adequate diameter to provide clearance between the chain and the body of the clutch.

- **Load**

Single strand sprockets, multiple strand sprockets, timing belt and v-belt pulleys, must be machined so that the chain or belt load is centered over the pilot bearings or pilot bushing.

- **Attachment**

- Screw Length: If too long, screws may interfere with the movement of the clutch plates. If too short and then the screws may shear under load due to inadequate thread engagement.
- Screw Tightening: screws which are either under-tightened or over-tightened are subject to breakage.

- **Alignment**

Improper alignment between mating sprockets or pulleys in the drive system will produce premature wear and possibly axial movement of the clutch on the drive shaft.

- **Chain & Belt Tension**

- Excessive chain or belt tension will cause premature wear of the bearings, bushing, sprocket or pulley and may cause clutches to continue driving when disengaged.
- Inadequate tension is indicated when belts and chains wear prematurely and disconnect from the pulleys and sprockets.

References and Resources

Sprockets & Chain

www.diamondchain.com

Pulleys & Belting

www.gates.com

Fasteners

www.unbrako.com