

Spring Applied Brake

Flange Mount



D4F3R-STH

Engagement/Disengagement

Spring/Air

Facing Type

High Coefficient

Torque – Dynamic

497 Pound Inches

Minimum Disengagement Pressure

53 PSI

Maximum Operating Pressure

80 PSI

Maximum RPM

1,750

Bore Range with Standard Keyway

0.625 (16) to 1.125 (28) Inches (mm)

Air Volume New

0.12 Cubic Inches

Air Volume Worn

0.36 Cubic Inches

Finish

Aluminum

Open or Enclosed Construction

Open

Mounting Bolt Circle

5.563 Inches

Shipping Weight

9 Pounds

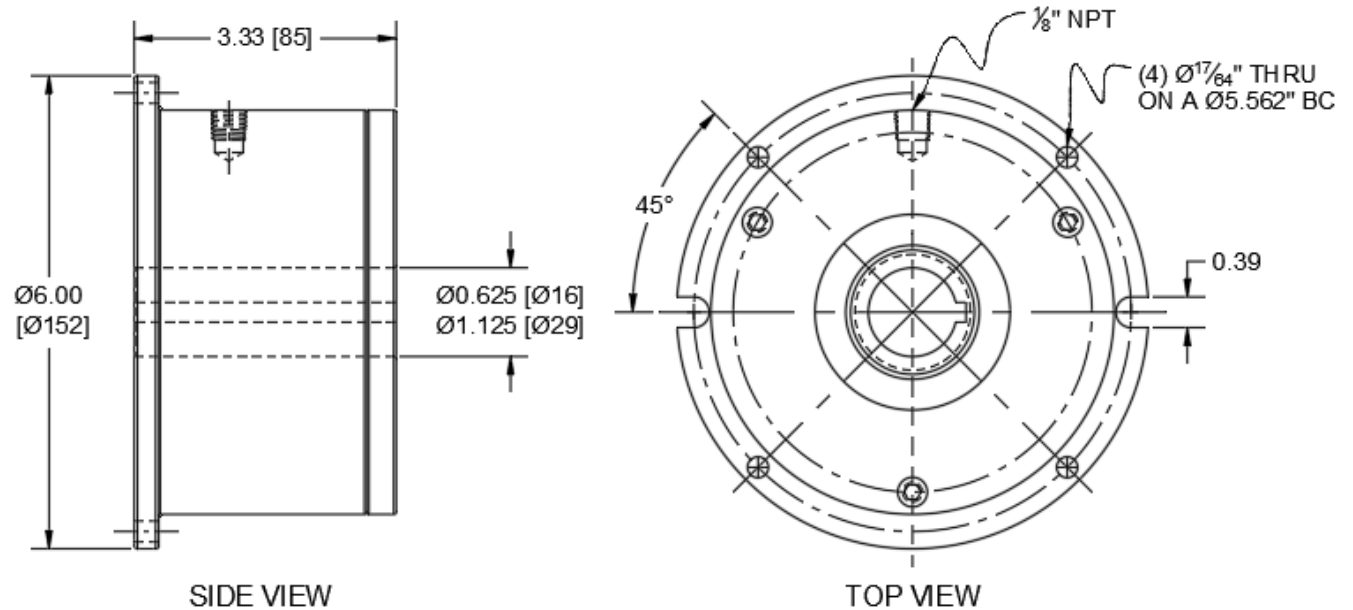

TORQUE vs. AIR PRESSURE

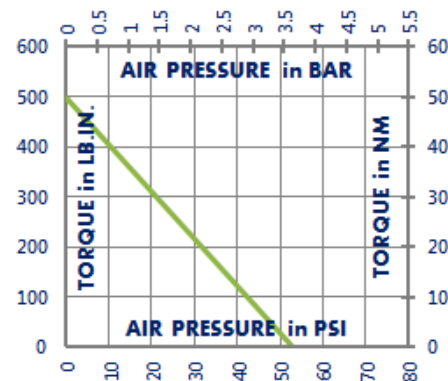

NEW vs. BURNISHED TORQUE

New clutch or brake torque is approximately 40% less than rated design torque until the friction and drive discs are worn in (lapped, burnished). The length of time for wear-in to occur varies by application.

When calculating required torque always use a service factor of 1.5 to 2. It is not recommended to select a product for use at its maximum rated torque for continuous duty.

PRODUCT SELECTION

Torque capacity is only one factor to consider when making a product selection. Insure that you will have right product for the job by contacting our engineering department for application review and selection assistance.



859-291-0849

engineering@machiii.com

www.machiii.com

D4F3R-STH

Parts Diagram

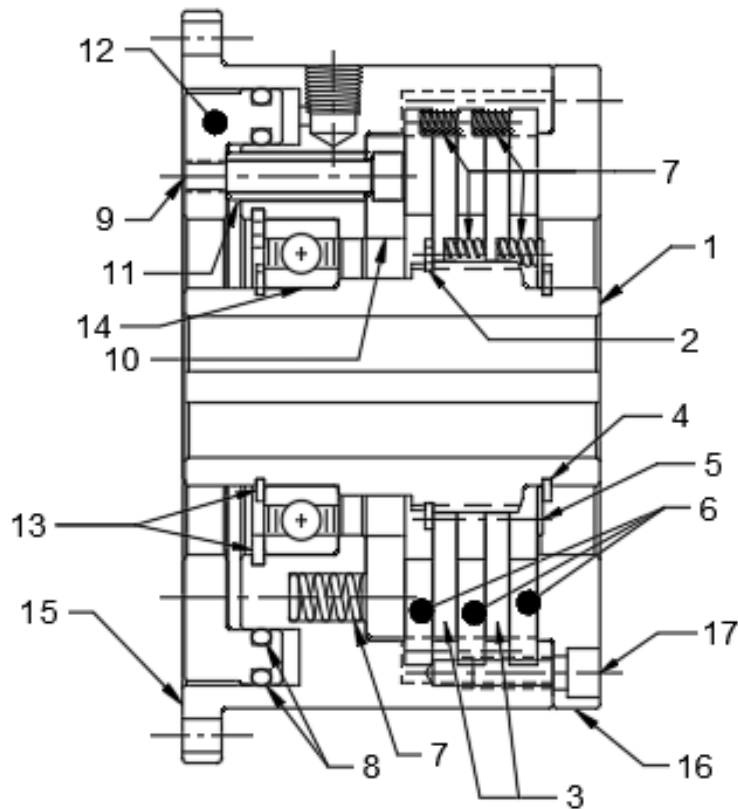

REF#	DESCRIPTION & PARTS INCLUDED	QUANTITY	KIT NUMBER
DRIVE HUB KIT			D4F3R-STH-HUBK
1	Drive Hub	1	<i>Specify Bore Size When Ordering</i>
2	Retainer Ring	1	
DRIVE DISC KIT			D4F3R-STH-DRDK
3	Drive Disc	2	
4	Retainer Ring	1	
5	Race	1	
REPAIR KIT			D3F3R-STH-RPRK
6	Friction Disc	3	
7	Coil Spring	21	
8	O-Ring	2	
PISTON KIT			D4F3R-STH-PSTK
9	Screw	3	
10	Pressure Plate	1	
11	Spacer	3	
12	Piston	1	
CYLINDER KIT			D4F3R-STH-CYLK
13	Retainer Ring	2	
14	Bearing	1	
15	Cylinder	1	
16	Top Plate	1	
17	Screw	3	

PARTS KITS

The *Repair Kit* contains common wear items for this product. Users are encouraged to stock one or more repair kits considering the number of units installed and the potential downtime if machinery on which the unit is installed is critical equipment. To obtain current pricing and lead time for parts kits, contact customer service.

orders@machiii.com

ADDITIONAL PRODUCT INFORMATION

Click on the links below or copy and paste into your web browser.

To view the Installation & Maintenance Manual for this product:

http://machiii.com/PDF/Product-Manuals/BRAKES_FLANGE_SPRING_MANUAL.pdf

For information about the application and use of this and other Mach III products:

<http://machiii.com/Application/Default.asp>



859-291-0849

engineering@machiii.com

www.machiii.com