

Friction Clutch – Air Applied
End of Shaft Bored, Pilot Mount



C8D3K-STH

Minimum Sprocket Sizes

Chain Size	50	60	80	100
Minimum Teeth	41	35	27	22

Engagement/Disengagement	Air/Spring
Facing Type	High Coefficient
Torque @ 80 PSI – Dynamic	14,855 Pound Inches
Minimum Engagement Pressure	3 PSI
Maximum Operating Pressure	80 PSI
Maximum RPM	1,325
Bore Range with Standard Keyway	2.000 (51) to 2.500 (66) Inches (mm)
Air Volume New	5.02 Cubic Inches
Air Volume Worn	16.53 Cubic Inches
Finish	Aluminum
Open or Enclosed Construction	Enclosed
Shipping Weight	62 Pounds

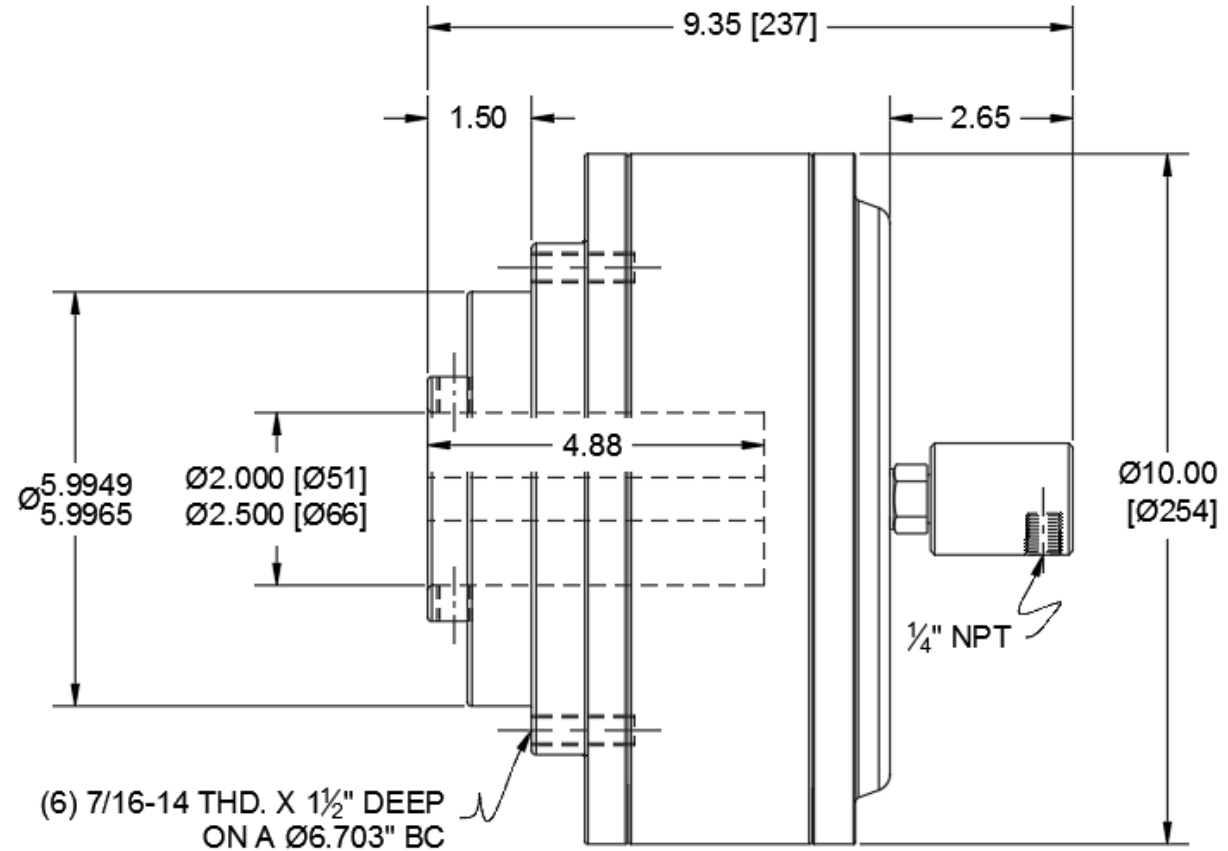

TORQUE vs. AIR PRESSURE

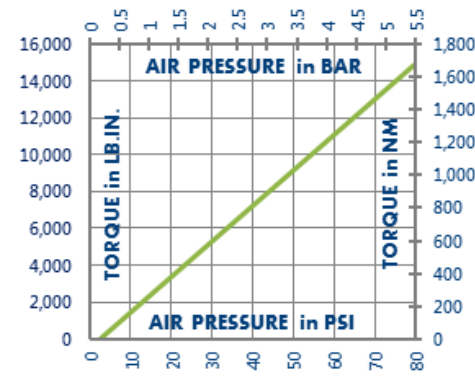

NEW vs. BURNISHED TORQUE

New clutch or brake torque is approximately 40% less than rated design torque until the friction and drive discs are worn in (lapped, burnished). The length of time for wear-in to occur varies by application.

When calculating required torque always use a service factor of 1.5 to 2. It is not recommended to select a product for use at its maximum rated torque for continuous duty.

PRODUCT SELECTION

Torque capacity is only one factor to consider when making a product selection. Insure that you will have right product for the job by contacting our engineering department for application review and selection assistance.



859-291-0849

engineering@machiii.com

www.machiii.com

C8D3K-STH

Parts Diagram

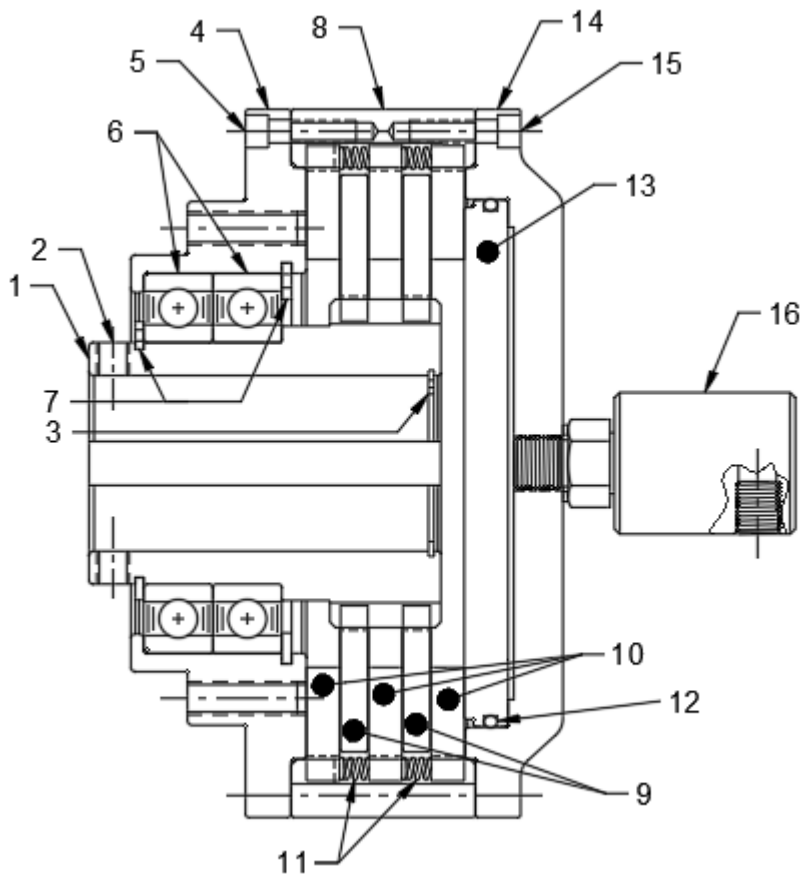

REF#	DESCRIPTION & PARTS INCLUDED	QUANTITY	KIT NUMBER
DRIVE HUB KIT			C8D3K-STH-HUBK
1	Drive Hub	1	<i>Specify Bore Size When Ordering</i>
2	Set Screw	2	
3	Retainer Ring	1	
SLEEVE KIT			C8D3K-STH-SLVK
4	Sleeve	1	
5	Screw	6	
6	Bearing	2	
7	Retainer Ring	2	
8		1	
DRIVE DISC KIT			C8D3K-STH-DRDK
9	Drive Disc	2	
REPAIR KIT			C8D3K-STH-RPRK
10	Friction Disc	2	
11	Coil Spring	12	
12	O-Ring	1	
PISTON KIT			C8D3K-STH-P004
CYLINDER KIT			C8D3K-STH-CYLK
14	Cylinder	1	
15	Screw	6	
16	ROTATING SEAL	1	QSLRT-008-11230-32

PARTS KITS

The *Repair Kit* contains common wear items for this product. Users are encouraged to stock one or more repair kits considering the number of units installed and the potential downtime if machinery on which the unit is installed is critical equipment. To obtain current pricing and lead time for parts kits, contact customer service.

orders@machiii.com

ADDITIONAL PRODUCT INFORMATION

Click on the links below or copy and paste into your web browser.

To view the Installation & Maintenance Manual for this product:

http://machiii.com/PDF/Product-Manuals/CLUTCH_ENDSHAFT_AIR_HD_MANUAL.pdf

For information about the application and use of this and other Mach III products:

<http://machiii.com/Application/Default.asp>



859-291-0849

engineering@machiii.com

www.machiii.com